

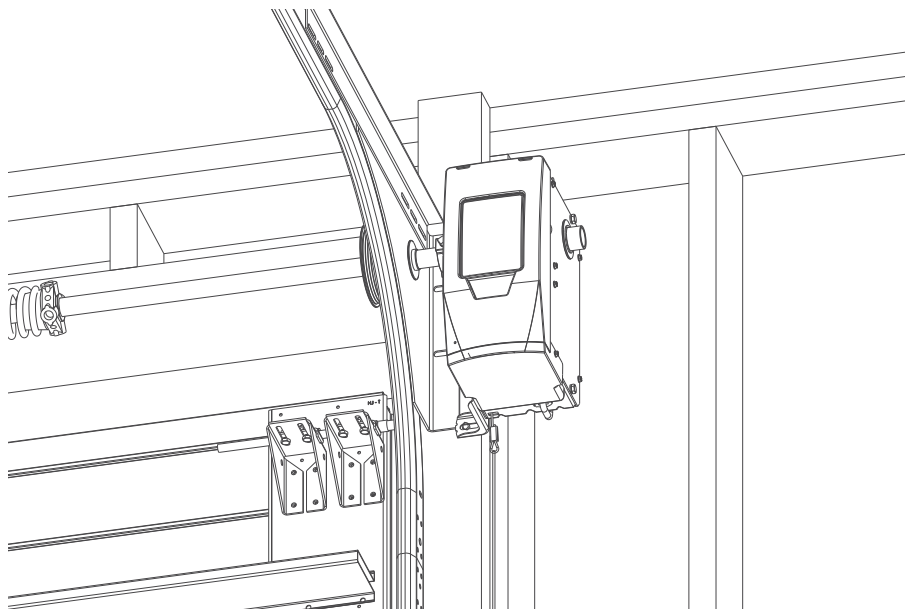

# RESIDENTIAL WALL MOUNT OPENER

## PROGRAMMING, OPERATION, TROUBLESHOOTING & MAINTENANCE MANUAL



**DO NOT** use photocells from other manufacturers or openers with this opener.

**INSTALLER: LEAVE THIS MANUAL WITH HOMEOWNER**

**HOMEOWNER: SAVE THIS MANUAL FOR FUTURE REFERENCE**

### **! WARNING**

To reduce the risk of injury to persons or damage to property, use this opener only with a residential sectional door with front torsion springs.

### **! AVERTISSEMENT**

Pour réduire le risque de blessures corporelles ou de dégâts matériels, utilisez cet ouvre-porte uniquement avec une porte sectionnelle résidentielle munie de ressorts de torsion avant.

SERIAL NUMBER DECAL

iDCM SERIAL NUMBER DECAL

©2024 GMI Holdings, Inc d/b/a The Genie Company, the Genie logo, Intellicode, Aladdin Connect, Safe-T-Reverse, SmartSet, Sure-Lock, Door Detect, and Safe-T-Beam, are trademarks of The Genie Company. All other trademarks are property of their rightful owners. Consistent with our policy of continuing product improvements, we reserve the right to change product specifications without prior notice or obligations. HomeLink is a registered trademark of Gentex Corporation. Car2U is a registered trademark of Lear Corporation.

39947.02080, 5/2024

# INDEX

## SAVE THESE INSTRUCTIONS

## READ AND FOLLOW ALL INSTRUCTIONS

<b>1</b>	<b>Standard &amp; Safety Features:</b> .....	1
<b>2</b>	<b>Safety &amp; General Information:</b>	
	Introduction .....	2
	Safety Notifications.....	2
	Important Installation Instructions.....	3
	Battery Safety Warnings.....	4
<b>3</b>	<b>Opener Installation:</b>	
	Pre-Installation Considerations.....	5
	Pre-Installation Permanent Input Wiring.....	6
	Installing Cable Keepers .....	7
	Installing Opener.....	8-10
	Installing Door Lock.....	11
<b>4</b>	<b>Wire Opener, Install &amp; Wire Accessories:</b>	
	Wire Door Lock.....	12
	Install And Wire Safe-T-Beam® .....	13
	Install Wireless Wall Console.....	14
	Install Led Light Fixture.....	14
	Install And Wire Optional Wired Wall Console .....	15
	Install And Wire Optional External Interlock .....	15
	Install Bottom Cover.....	15
	Apply Power To Opener .....	16
<b>5</b>	<b>Programming Opener And Accessories:</b>	
	Introduction .....	17
	Adjusting For Drum Selection .....	18
	Setting Down Limit.....	19
	Setting Up Limit.....	20
	Setting Force Control And Contact Reverse .....	21
	Programming Additional Remote Controls .....	22
	<b>Programming Accessories:</b>	
	Wireless Keypad* .....	23
	Programming Vehicle Controls* .....	24
	Programming Aladdin Connect® .....	25-26
<b>6</b>	<b>Special Installation Information:</b>	
	Changing Force Settings .....	27
	Clearing Remote/Accessory Memory .....	28
	Locating Safe-T-Beam® (multiple doors) .....	29
	Safe-T-Beam® Troubleshooting .....	29
	Installing Battery Back Up .....	30
	Adding & Programming	
	Additional Accessories .....	31
<b>7</b>	<b>Maintenance:</b>	
	Important Safety Instructions.....	32
	Regular Maintenance Schedule .....	33
	Door Inspection & Maintenance.....	33
	Remote Battery Replacement.....	33
<b>8</b>	<b>Troubleshooting &amp; LED Signals</b> .....	34-36
<b>9</b>	<b>Replacement Parts</b> .....	37-39
<b>10</b>	<b>DASMA Information</b> .....	40-41

### FCC Part 15.21 Statement:

Changes or modifications not expressly approved by the party responsible for compliance could void the user's authority to operate the equipment.

### FCC / IC Statement:

This device complies with FCC Part 15 and Industry Canada licence-exempt RSS standard(s). Operation is subject to the following two conditions: (1) this device may not cause harmful interference, and (2) this device must accept any interference received, including interference that may cause undesired operation of the device.

Le présent appareil est conforme aux CNR d'Industrie Canada applicables aux appareils radio exempts de licence. L'exploitation est autorisée aux deux conditions suivantes : (1) l'appareil ne doit pas produire de brouillage, et (2) l'utilisateur de l'appareil doit accepter tout brouillage radioélectrique subi, même si le brouillage est susceptible d'en compromettre le fonctionnement.

For patent info visit  
[www.geniecompany.com/patents](http://www.geniecompany.com/patents)

\* Abbreviated versions. See instructions that accompany ACCESSORY or VEHICLE OWNERS MANUAL for full details, WARNINGS, CAUTIONS and instructions.

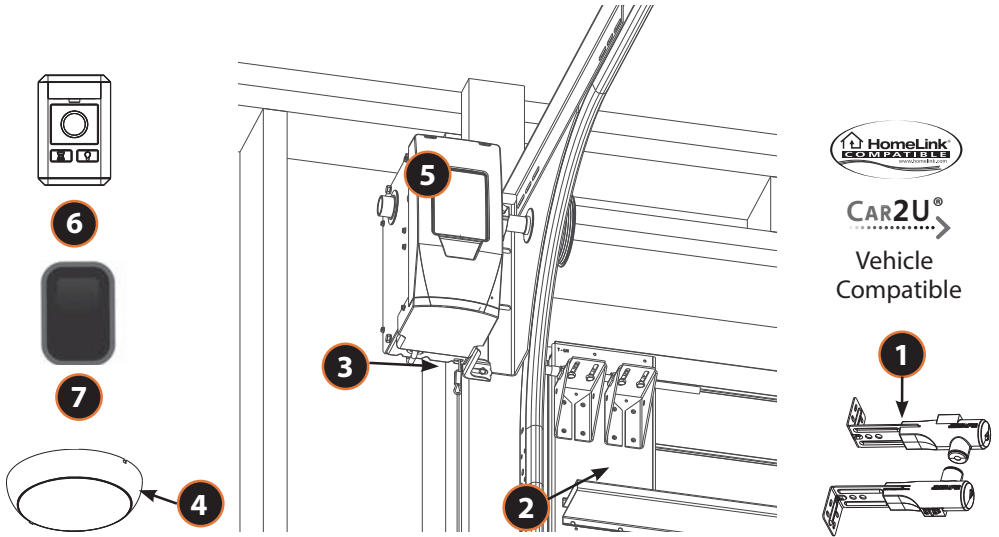

### 1. Safe-T-Beam® (STB) Non-Contact Reversing System:

- Places an infrared beam across the door opening.
- Only affects the DOWN travel of the door.
- Stops an open door from closing or reverses a door while in the down travel.
- Reversing system can be overridden with constant pressure on the wired wall console only.
- The door will stop and reverse to the full open position if beam is obstructed.
- Self-diagnostic LEDs on STBs and Powerhead alert to operational issues (See *Locating Safe-T-Beam® (for multiple doors) & Troubleshooting* section in this manual for more information).

### 2. Contact Reversing System:

- Force control automatically reverses a closing door upon contact with an obstruction.

### 3. Manual Emergency Release pull handle & cord:

- Manually releases door from door opener. Used during a power failure or other emergency to allow manual opening and closing of the door.

### 4. Automatic LED Light Fixture:

- Lighting Fixture turns ON when door is activated and automatically turns OFF 4 minutes later.
- Can be activated/deactivated manually from the wall console.

### 5. Integrated Aladdin Connect™ :

- Available with select models, allows operation of the garage door opener with a secure mobile device application (app) from Aladdin Connect™.

### 6. Wireless Wall Console:

- Wireless Wall Console operates door opener from inside garage with an open/close button.
- Manual light control and override.
- OPEN/CLOSE Delay button. Adds an operation delay. Press once for 10 seconds, twice for 20 seconds, three times for 30 seconds.

### 7. IntelliCode® Encryption, Factory Programmed Remote(s) :

- An encryption system that enhances the security of the door opener by continuously changing the access code each time the remote is used.
- Factory programmed remote control(s) included with this opener.

### Not Shown- Battery Backup (Included on select models) :

- Mounts to bottom of opener and provides power for opener operation during power outages.

## 2 SAFETY NOTIFICATIONS & INSTRUCTIONS

### OVERVIEW OF POTENTIAL HAZARDS

#### READ THIS SAFETY INFORMATION

Garage doors are large, heavy objects that move with the help of springs under high tension and electric motors. Since moving objects, springs under tension, and electric motors can cause injuries, your safety and the safety of others depend on you reading the information in this manual. If you have questions or do not understand the information presented, call your nearest trained door system technician or visit our website at [www.geniecompany.com](http://www.geniecompany.com).

#### CONVENTIONS USED IN THESE INSTRUCTIONS

The following safety alert symbol and signal words are used throughout this manual to call attention to and identify different levels of hazards and special instructions.

This is the safety alert symbol. This symbol alerts you to potential hazards that can kill or hurt you and others. All safety messages will follow the safety alert symbol and the word "DANGER", "WARNING", or "CAUTION".



- **DANGER** indicates an imminently hazardous situation which, if NOT avoided, will result in death or serious injury.
- **WARNING** indicates a potentially hazardous situation which, if NOT avoided, could result in death or serious injury.
- **CAUTION** indicates a potentially hazardous situation which, if NOT avoided, may result in injury or property damage.
- The word **NOTE** is used to indicate important steps to be followed or important considerations.

Tous les messages concernant la sécurité seront indiqués après un symbole d'alerte de la sécurité et l'une des mentions suivantes "DANGER", "AVERTISSEMENT" ou "MISE EN GARDE".



- **DANGER** signale une situation dangereuse imminente qui, si elle n'est pas évitée, risque d'entraîner des blessures graves, voire mortelles.
- **AVERTISSEMENT** signale une situation potentiellement dangereuse qui, si elle n'est pas évitée, risque d'entraîner la mort ou des blessures graves.
- **MISE EN GARDE** signale une situation potentiellement dangereuse qui, si elle n'est pas évitée, risque d'entraîner des blessures ou des dommages matériels.
- Le terme **REMARQUE** est utilisé pour signaler les étapes importantes à suivre ou d'importants éléments à prendre en considération.

## IMPORTANT SAFETY INSTRUCTIONS

POTENTIAL HAZARD	EFFECT	PREVENTION
<b>MOVING DOOR</b> 	<b>WARNING</b> Could result in Serious Injury or Death	Do Not operate unless the doorway is in sight and free of obstructions. Keep people clear of opening while door is moving. Do Not allow children to play with the door opener. Do Not change opener control to momentary contact unless an external reversing means is installed. Do Not operate a door that jams or one that has a broken spring.
<b>ELECTRICAL SHOCK</b> 	<b>WARNING</b> Could cause Serious Injury or Death	Turn off electrical power before removing opener cover. When replacing the cover, make sure wires are not pinched or near moving parts. Opener must be electrically grounded.
<b>HIGH SPRING TENSION</b> 	<b>WARNING</b> Could cause Serious Injury or Death	Do Not try to remove, repair or adjust springs or anything to which door spring parts are fastened such as wood block, steel brackets, cables or any other structure or like item. Repairs and adjustments must be made by a trained service representative using proper tools and instructions.

## IMPORTANTES CONSIGNES DE SÉCURITÉ

DANGER POTENTIEL	EFFET	PRÉVENTION
<b>PORTE EN MOUVEMENT</b> 	<b>AVERTISSEMENT</b> Pourrait entraîner des blessures graves voire la mort	Utiliser uniquement si la porte est en vue et libre de tout obstacle. Ne laisser personne se tenir dans l'ouverture de la porte pendant qu'elle est en mouvement. Ne pas permettre aux enfants de jouer avec l'opérateur de la porte. Ne pas modifier la commande de l'opérateur à contact momentané à moins qu'un moyen d'inversion externe soit installé. Ne pas faire fonctionner une porte qui bloque ou dont le ressort est cassé.
<b>CHOC ÉLECTRIQUE</b> 	<b>AVERTISSEMENT</b> Pourrait entraîner des blessures graves voire la mort	Couper le courant avant d'enlever le couvercle de l'opérateur. Lorsque le couvercle doit être remplacé, s'assurer que les fils ne sont ni coincés ni près des pièces mobiles. L'opérateur doit être correctement mis à la terre.
<b>TENSION ÉLEVÉE RESSORT</b> 	<b>AVERTISSEMENT</b> Pourrait entraîner des blessures graves voire la mort	Ne pas essayer d'enlever, réparer ni ajuster les ressorts ou toute autre pièce à laquelle le ressort de la porte est attaché, y compris blocs de bois, supports en acier, câbles ou autres articles semblables. Les réparations et les réglages doivent être effectués par technicien qualifié qui se sert d'outils appropriés et qui respecte les instructions.

# IMPORTANT INSTALLATION INSTRUCTIONS



## WARNING

### TO REDUCE THE RISK OF SEVERE INJURY OR DEATH

READ AND FOLLOW ALL SAFETY, INSTALLATION AND OPERATION INSTRUCTIONS. If you have any questions or do not understand an instruction, call The Genie Company.

- **DO NOT** install opener on an improperly balanced door. An improperly balanced door could cause severe injury. Repairs and adjustments to cables, spring assembly and other hardware must be made by a trained service person using proper tools and instructions.
- Remove all ropes, and disable all locks connected to the door before installing opener.
- Where possible, install the door opener 7 feet or more above the floor. For products having an emergency release, mount the emergency release within reach, but at least 6 feet above the floor and avoiding contact with vehicles to avoid accidental release. **DO NOT** use emergency release cord to pull door.
- **DO NOT** connect the opener to the source of power until instructed to do so.
- Locate the wall control button: A) Within sight of door. B) At a minimum height of 5 feet, so small children cannot reach it. C) Away from all moving parts of the door.
- Install the entrapment WARNING label next to the wall button or console, in a prominent location. Install the emergency release handle on the emergency release cord.
- The opener must reverse when the door contacts a 1-1/2 inch high object on the floor at the center of the doorway. This is about the size of a 2" x 4" board laid flat.

# IMPORTANTES INSTRUCTIONS D'INSTALLATION



## AVERTISSEMENT

### POUR RÉDUIRE LES RISQUES DE BLESSURES GRAVES VOIRE MORTELLES

LIRE ET SUIVRE ATTENTIVEMENT TOUTES LES INSTRUCTIONS D'INSTALLATION ET DE FONCTIONNEMENT AINSI QUE TOUTES LES CONSIGNES DE SÉCURITÉ. Si vous avez des questions ou si vous ne comprenez pas une instruction, veuillez contacter directement The Genie Company.

- **NE PAS** installer l'opérateur sur une porte mal équilibrée. Celle-ci pourrait entraîner de graves blessures. Les réparations et les réglages des câbles, ensembles de ressort ou tout autre article de quincaillerie doivent être effectués par un professionnel qui se sert d'outils appropriés et qui respecte les instructions.
- Enlever toutes les cordes et désactiver toutes les verrous de la porte avant l'installer l'opérateur.
- Dans la mesure du possible, installer l'ouvre-porte à 2,1 m ou plus au-dessus du sol. Pour les produits dotés d'un cordon de déclenchement d'urgence, installer le déclenchement d'urgence mais au moins à 1,8 m au-dessus du sol en évitant tout contact avec les véhicules pour éviter qu'ils ne soient déclenchés accidentellement. **NE PAS** utiliser d'urgence cordon de libération pour ouvrir ou fermer la porte.
- **NE PAS** connecter l'opérateur à la source d'alimentation tant que l'instruction n'est pas donnée.
- Repérer la console murale: A) En vue de la porte. B) À une hauteur minimale de 1,5 m afin que les jeunes enfants ne puissent pas l'atteindre. C) Loin de toutes pièces mobiles de la porte du garage.
- Placer l'étiquette d'AVERTISSEMENT en cas de coinçage à proximité du bouton mural ou de la console de manière à ce qu'elle soit bien en évidence. Installer la poignée du cordon de déclenchement d'urgence.
- L'opérateur doit s'inverser lorsque la porte entre en contact avec un objet d'une hauteur de 3,8 cm placé sur le sol, au centre de l'ouverture de la porte. Ceci équivaut environ à une planche de 5 x 10 cm posée à plat sur le sol.



## WARNING

Opener is equipped with grounded electrical plug for your protection, and **only fits grounded electrical outlets. DO NOT** alter plug in any way! **If your have no grounded outlets, have one installed by a licensed electrician.** Opener must be properly grounded to prevent personal injury and equipment damage. **NEVER USE AN EXTENSION CORD!** Check local building codes for any requirement that you must have a permanent hard-wired connection. Permanent hard-wired connections must be performed by a licensed electrician using proper tools and instructions.



## AVERTISSEMENT

L'opérateur, qui est équipé d'une prise électrique mise à la terre pour votre protection **est compatible uniquement avec des prises électriques mises à la terre. NE PAS** modifier la fiche d'une quelconque manière. Si vous n'avez pas de prises mises à la terre, faites-en installer par un électricien agréé. L'opérateur doit être correctement mis à la terre pour éviter les blessures corporelles et des dommages matériels. **NE JAMAIS UTILISER DE RALLONGE!** Vérifiez les codes locaux des bâtiments pour connexions câblées permanente. Les connexions câblées permanentes doivent être effectuées par un électricien agréé qui se servira d'outils appropriés et respectera les consignes.

# BATTERY SAFETY WARNINGS



## WARNING

- **INGESTION HAZARD:** this product contains a button cell or coin battery.
- **DEATH** or serious injury can occur if ingested.
- A swallowed button cell or coin battery can cause Internal Chemical Burns in as little as 2 hours.
- **KEEP** new and used batteries **OUT OF REACH OF CHILDREN**
- Seek immediate medical attention if a battery is suspected to be swallowed or inserted inside any part of the body.



- Remove and immediately recycle or dispose of used batteries according to local regulations and keep away from children.
- Do NOT dispose of batteries in household trash or incinerate.
- Even used batteries may cause severe injury or death.
- Call a local poison control center for treatment information.
- Replace only with Type CR2032 3V batteries.
- Non-rechargeable batteries are not to be recharged.
- Do not force discharge, recharge, disassemble, heat above (manufacturer's specified temperature rating) or incinerate. Doing so may result in injury due to venting, leakage or explosion resulting in chemical burns.
- Ensure the batteries are installed correctly according to polarity (+ and -).
- Do not mix old and new batteries, different brands or types of batteries, such as alkaline, carbon-zinc, or rechargeable batteries.
- Remove and immediately recycle or dispose of batteries from equipment not used for an extended period of time according to local regulations.
- Always completely secure the battery compartment. If the battery compartment does not close securely, stop using the product, remove the batteries, and keep them away from children.



## AVERTISSEMENT

- **DANGER D'INGESTION :** Ce produit contient une pile bouton ou une pile bouton.
- La **MORT** ou des blessures graves peuvent survenir en cas d'ingestion.
- Une pile bouton ou une pile bouton avalée peut provoquer des dommages chimiques internes brûle en seulement 2 heures.
- **GARDER** les piles neuves et usagées **HORS DE LA PORTÉE DES ENFANTS**
- Consultez immédiatement un médecin si vous soupçonnez qu'une batterie est avalé ou inséré dans n'importe quelle partie du corps.



- Retirez et recyclez ou jetez immédiatement les piles usagées conformément aux réglementations locales et gardez-les hors de portée des enfants. Ne jetez PAS les piles avec les ordures ménagères ou ne les incinerez pas.
- Même les piles usagées peuvent provoquer des blessures graves, voire la mort.
- Appelez un centre antipoison local pour obtenir des informations sur le traitement.
- Remplacez uniquement par des piles de type CR2032 3 V.
- Les piles non rechargeables ne doivent pas être rechargées.
- Ne forcez pas la décharge, la recharge, le démontage, la chaleur au-dessus de la température nominale spécifiée par le fabricant et l'incinération. Cela pourrait entraîner des blessures dues à une ventilation, une fuite ou une explosion entraînant des brûlures chimiques.
- Assurez-vous que les piles sont installées correctement selon la polarité (+ et -).
- Ne mélangez pas des piles anciennes et neuves, des marques ou des types de piles différents, tels que des piles alcalines, carbone-zinc ou rechargeables.
- Retirez et recyclez ou jetez immédiatement les batteries des équipements non utilisés pendant une période prolongée, conformément aux réglementations locales.
- Sécurisez toujours complètement le compartiment à piles. Si le compartiment des piles ne se ferme pas correctement, arrêtez d'utiliser le produit, retirez les piles et gardez-les hors de portée des enfants.

## Compatibility Considerations:

The light-duty jackshaft operator is intended for use on:

- Standard lift up to 14 feet tall, using industry standard APCO 400.8 , 400.12 and 5250.18 drums or equivalent.
- Hi-lift sectional doors up to 14 feet tall and 84 inches maximum of high lift using industry standard APCO 400.54 , 5250.54 and 500.84 drums or equivalent.
- Vertical lift doors up to 14' tall, using industry standard APCO 850.11 and 1100.18 drums or equivalent.
- Doors up to 18' wide not to exceed 180 square feet and 850 lbs. balance weight.
- Only doors that use torsion springs with a torsion bar diameter of 1" solid or hollow 14 or 16 ga. tubular steel.
- Not compatible with low headroom outside hook-up, i.e. reverse wound drums.

### ⚠ WARNING

- Garage door hardware (springs, cables, brackets, pulleys, etc.) are under extreme pressure and tension.
- **DO NOT** attempt to repair or adjust door springs or any hardware, and **DO NOT OPERATE** garage door automatically or manually if door is improperly balanced or springs are broken.
- **CONTACT A TRAINED DOOR SYSTEM TECHNICIAN.**

### ⚠ AVERTISSEMENT

- La quincaillerie de la porte de garage (ressorts, câbles, supports, poulies, etc.) sont sous des pressions et des tensions extrêmes.
- **NE PAS** réparer ni régler les ressorts de la porte ou toute autre pièce de quincaillerie et **NE PAS ACTIONNER** la porte manuellement ou automatiquement si elle n'est pas correctement équilibrée ou si des ressorts sont cassés.
- **CONTACTEZ UN TECHNICIEN SPÉCIALISÉ EN SYSTÈME DE PORTES**

## Door Inspection:

If the intended door meets the above requirements, inspect the door for proper balance and general condition.

- Raise and lower the door manually. Door should move freely and smoothly.
- Raise door manually about 3' to 4' from floor and let go. Door should remain stationary or slowly drift closed. Fig.A.
- If door opens or closes rapidly, **CONTACT A TRAINED DOOR SYSTEM TECHNICIAN** to have your door springs serviced.
- Disable or remove ropes attached to the door and any locks which will not be interlocked with the operator.
- Monitor the end of the torsion bar while the door is raised and lowered. It is important that there is no noticeable movement up and down or side to side, if there is, **CONTACT A TRAINED DOOR SYSTEM TECHNICIAN**, otherwise operator reliability will be significantly reduced.

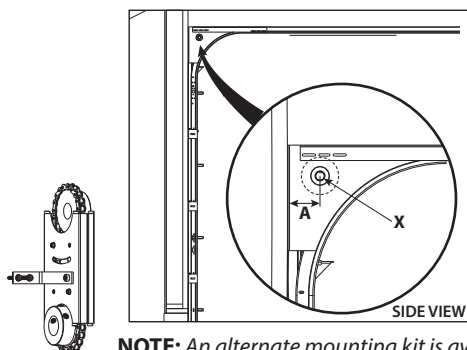

Fig. A

## Critical Measurements:

This operator can be installed left or right-handed. Critical measurements must be taken to ensure this operator will fit the intended door.

- This operator will directly couple onto torsion shafts, solid or tubular, of 1" in diameter with or without a keyway. (X)
- Measure the distance between the torsion bar centerline to the wall. This dimension must be between 2-1/2" and 6". (A)
- The torsion bar shaft must protrude no less than 2-1/4" from bearing plate. (B)
- A standard 115 VAC grounded electrical outlet will be required within 5' of the bottom of the operator.
- Torsion bar centerline to the ceiling must be at least 2-1/4" for clearance. (C) Note: Headroom required is less than smallest standard drum (400.8).
- End of torsion shaft to side wall clearance must be at least 7" for clearance. (D)



**NOTE:** An alternate mounting kit is available for applications requiring indirect chain couple.  
P/N 40803R

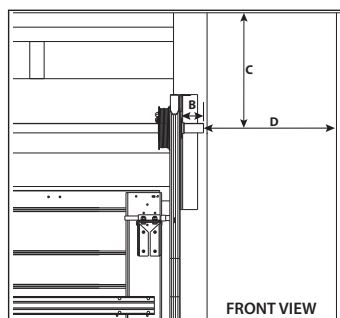



# PRE-INSTALLATION CONSIDERATIONS

## (INPUT POWER WIRING OPTIONS)

### Input Power Options:

#### A. 115 VAC plug Provided with Operator

1. A 115 VAC power outlet must be available within 5' from bottom of the operator when mounted to door.
2. Continue installation starting on page 8.

#### B. Power Extension Kit P/N: 41194R.S

The power extension kit includes a 115 VAC plug, transformer box, 30' of low voltage cable, and a circuit board that replaces the transformer in the operator. This kit may be installed by a garage door technician in jurisdictions which do not require a licensed electrician to install low voltage circuits.

3. Follow installation instructions included with the power extension kit.
4. Continue installation starting on page 8.

#### C. Permanent wiring should be completed by a trained electrician only:

1. Remove two screws from bottom of cover and remove main operator cover/circuit board assembly.
2. Unplug wire harnesses from main board.
3. Unplug input power cable connector from transformer input.
4. Remove transformer from chassis.
5. Remove strain relief and pull power cable from operator.
6. Install operator per instructions on pages 8 through 10.
7. Cut power cable wires and strip insulation from power cable input harness connector end.
  - All wire connections must be made **INSIDE CHASSIS** and there must be at least 3" of new power supply line wire inside chassis.
  - Check local code for the use of conduit or other protective material.
  - Conduit, fittings/strain relief, and wire nuts are not provided.
8. Install 1/2" NPT or other suitable connector into chassis. (Adhere to local electrical code(s) and regulations)
9. Connect permanent power input cable to harness wires using approved connectors or wire nuts (Adhere to local electrical code(s) and regulations)
10. Install ground connector to permanent power cable ground wire.
11. Install ground screw and power cable ground onto chassis.
12. Plug power input harness into transformer harness.
13. Install transformer.
14. Ensure input power cable and connections do not interfere with internal moving components.
15. Plug all harnesses into main control board and install cover assembly.
16. **DO NOT APPLY POWER AT THIS TIME.**
17. Continue installation starting on page 8.

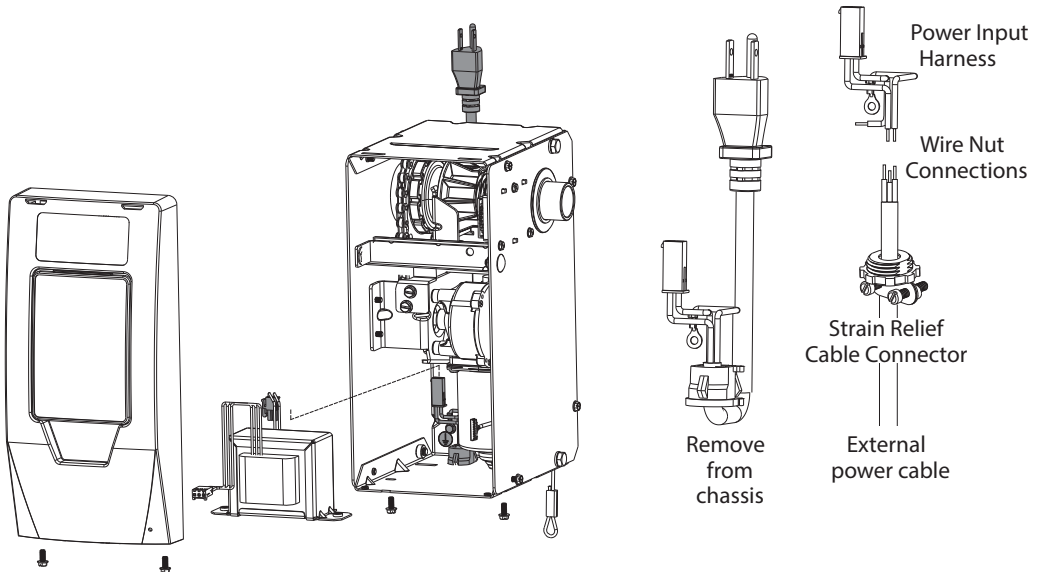



# INSTALLING CABLE KEEPERS

## ⚠ WARNING

- Operating a door with frayed or broken counterbalance lift cables can result in severe or fatal injury.
- Contact a qualified door service company to replace frayed or broken cables before installing cable keepers.

## ⚠ AVERTISSEMENT

- Faire fonctionner une porte avec des câbles de levage à contrepoids effilochés ou cassés peut entraîner des blessures graves, voire mortelles.
- Contactez une société qualifiée en réparations de portes pour remplacer les câbles effilochés ou cassés avant d'installer des protège-câbles.

## ⚠ WARNING

- Do not attempt to loosen or remove bottom corner brackets. They are under extreme spring tension and can cause severe or fatal injury.

## ⚠ AVERTISSEMENT

- N'essayez pas de desserrer ou de retirer les supports en cornière inférieurs. Ils sont soumis à une tension de ressort extrême et peuvent causer des blessures graves, voire mortelles.

1. Carefully inspect the counterbalance lift cables on the door. If they are worn, frayed or broken, contact a qualified door service company to replace the counterbalance lift cables before installing the cable keepers.
2. Push spacer onto the shaft between the short stem track roller and the bottom corner bracket. Use an additional spacer if needed to achieve a minimum of 1/2" clearance.
3. If there is less than 1/2" clearance, loosen the lag screws attaching the track to the wall and adjust the track for the 1/2" clearance. Re-tighten the lag screws.
4. Position the right-hand (black) cable keeper assembly directly above the garage door bottom corner bracket.
5. The cable keeper assembly must extend 1/8" past the end of the door section. Ensure there is no more than 4-1/2" from the bottom edge of the door to bottom of cable keeper.

### IMPORTANT: RIGHT AND LEFT-HAND IS ALWAYS DETERMINED FROM INSIDE THE BUILDING LOOKING OUT.

6. Fasten the cable keeper assembly with (2) 1/4" - 20 x 11/16" self-drilling screws (wood doors will use (2) 1/4" x 1" lag screws).
7. Once the cable keeper assembly is secured to the bottom section, place the plastic sleeve over the counterbalance lift cable and then rotate the cable keeper arm upward and attach it to the plastic sleeve.
8. Repeat the same process for the left-hand (Red) cable keeper assembly.

**NOTE:** It is recommended that wood doors be pre-drilled with 1/8" pilot holes prior to fastening.

**IMPORTANT NOTE:** Operate door manually, full open to full close, and monitor keeper to ensure that it does not contact door track. Adjust as necessary.

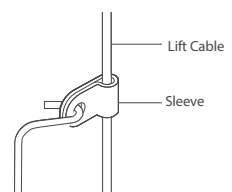
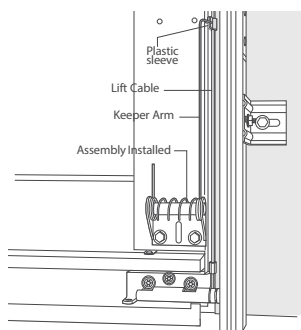
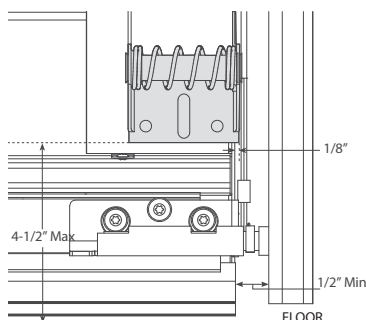
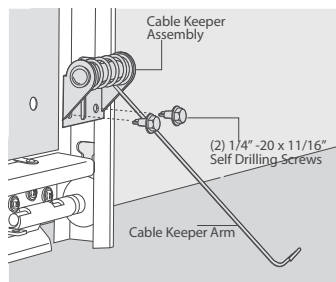
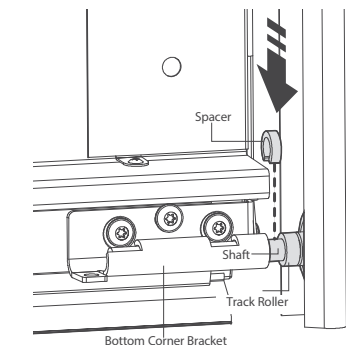

# INSTALLING THE OPENER

1. Close door.
2. Remove bolt and lock washer (A) from powerhead chassis and loosely install mounting bracket from kit bag on desired side of powerhead. (right hand mount shown).

**NOTE:** Bracket can be mounted to operator on either side depending on mounting requirements.

3. Install Coupler
  - Tighten or loosen all 6 bolts until they are flush with the couplers internal bore or top of keyway if using on solid shaft with a keyway. (See **DETAIL A**).
  - Add 1 full turn to operator output shaft bolts.
  - Add 1 full turn to tubular door shaft bolts or 1/2 turn to solid door shaft bolts.

**NOTE:** Coupler bolts include thread locking compound.

**NOTE:** Coupler bolts use 1/2" wrench or socket.

**NOTE:** The coupler must be installed onto the operator output shaft until the coupler seats completely to the recess inside coupler.

**NOTE:** Operator **MUST** be mounted to garage framing material. **DO NOT** install to particle board or drywall.

**NOTE:** Alternate installation method: If dimension D (page 5) is less than 8", install coupler onto door shaft first.

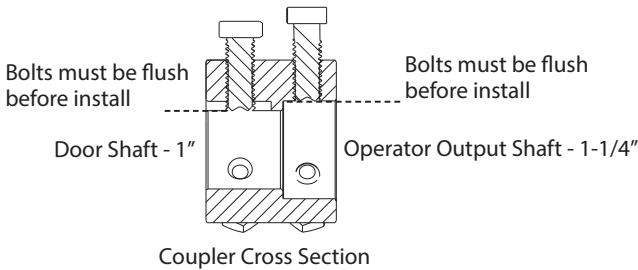

Coupler Cross Section

**DETAIL A**

7/16"  
SOCKET

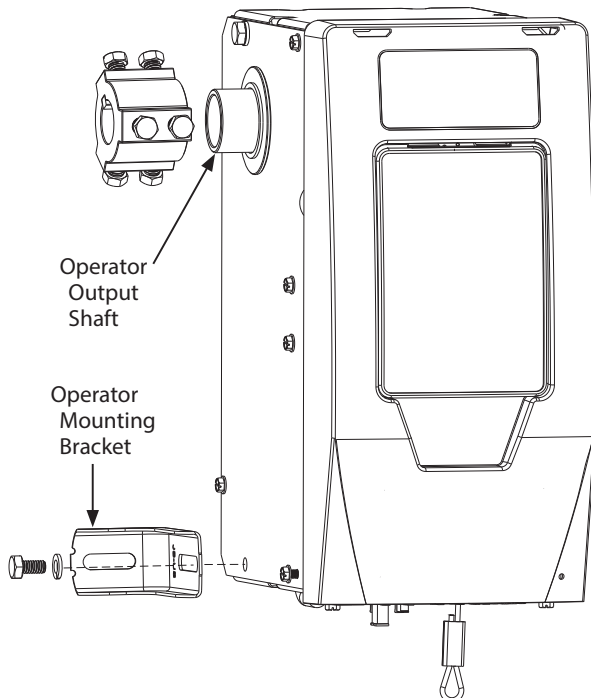

# INSTALLING THE OPENER (CONT')

4. Mount operator to door shaft.
  - If the door shaft is NOT keyed, slide operator assembly onto door shaft and tighten setscrews finger tight.
  - If the door shaft IS keyed, insert provided key into either keyway. Pull emergency release cable at the bottom of the operator to allow free rotation of the output shaft to "clock" the keyways together.
5. Tighten set screws onto door shaft finger tight.

**NOTE:** The mounting of this operator to the door shaft is designed so the door shaft will slide through the coupler and enter the hollow output shaft of the operator up to 3 -3/8" (there is a stop pin located in the center of the operator output shaft).

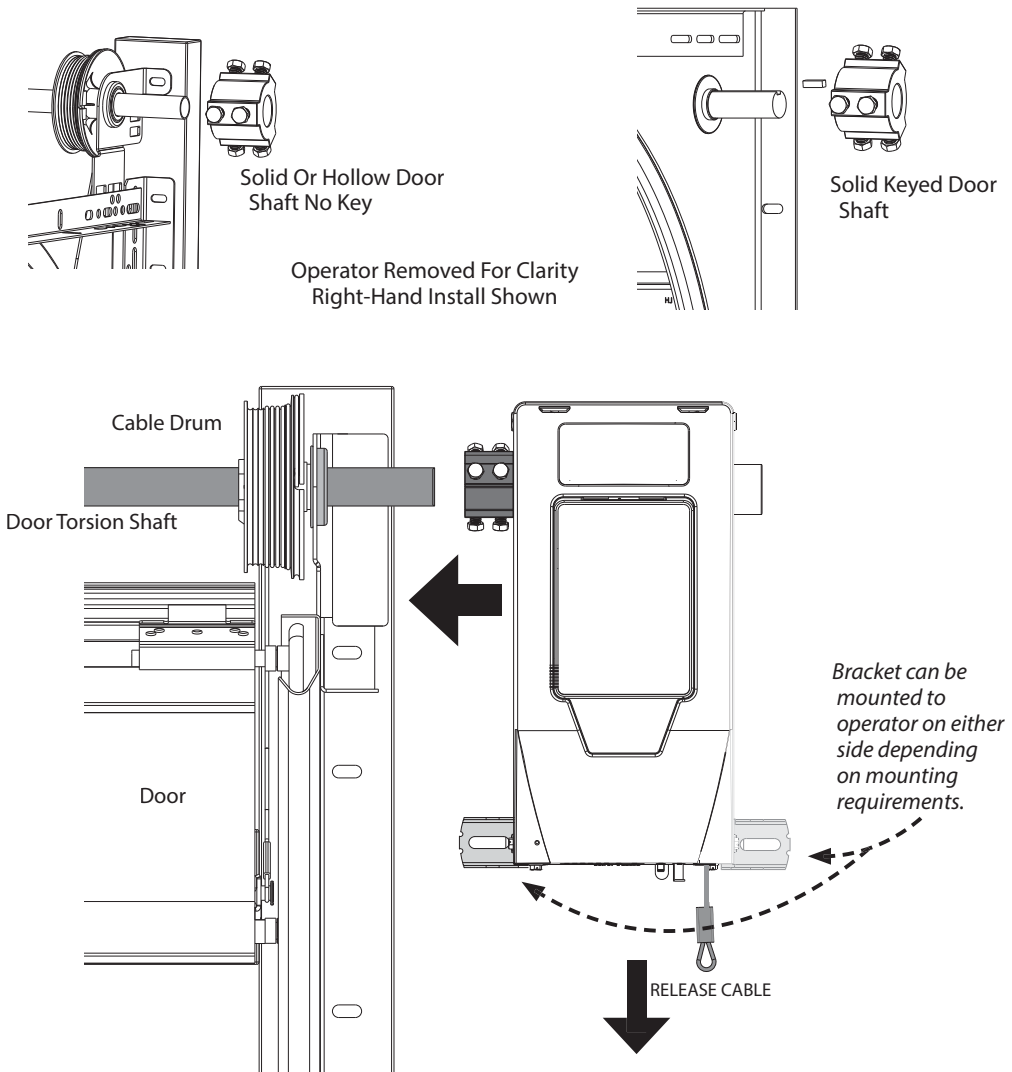

## INSTALLING THE OPENER (CONT')

6. Level and square operator.
7. Mark mounting bracket hole position, pre-drill a 3/16" pilot hole and install lag screw and fully tighten.
8. Leave at least a 1/4" gap between coupler and door shaft bearing.
9. Add 1 full turn on each coupler set screw.
10. Tighten mounting bracket bolt to operator.
11. Pull emergency release cable and manually operate door to inspect for binding.
12. Tie red emergency release cord to cable loop and tie release handle to cord approximately 5' from floor.

**NOTE:** Ensure all coupler bolts are secured prior to tightening mounting bracket bolt.

**NOTE:** Operator **MUST** be mounted to garage framing material. **DO NOT** install to particle board or drywall.

The instructions above are provided using standard wood framing and bracing. Additional bracing may be required for this installation.

Hardware for masonry or steel construction is not provided.

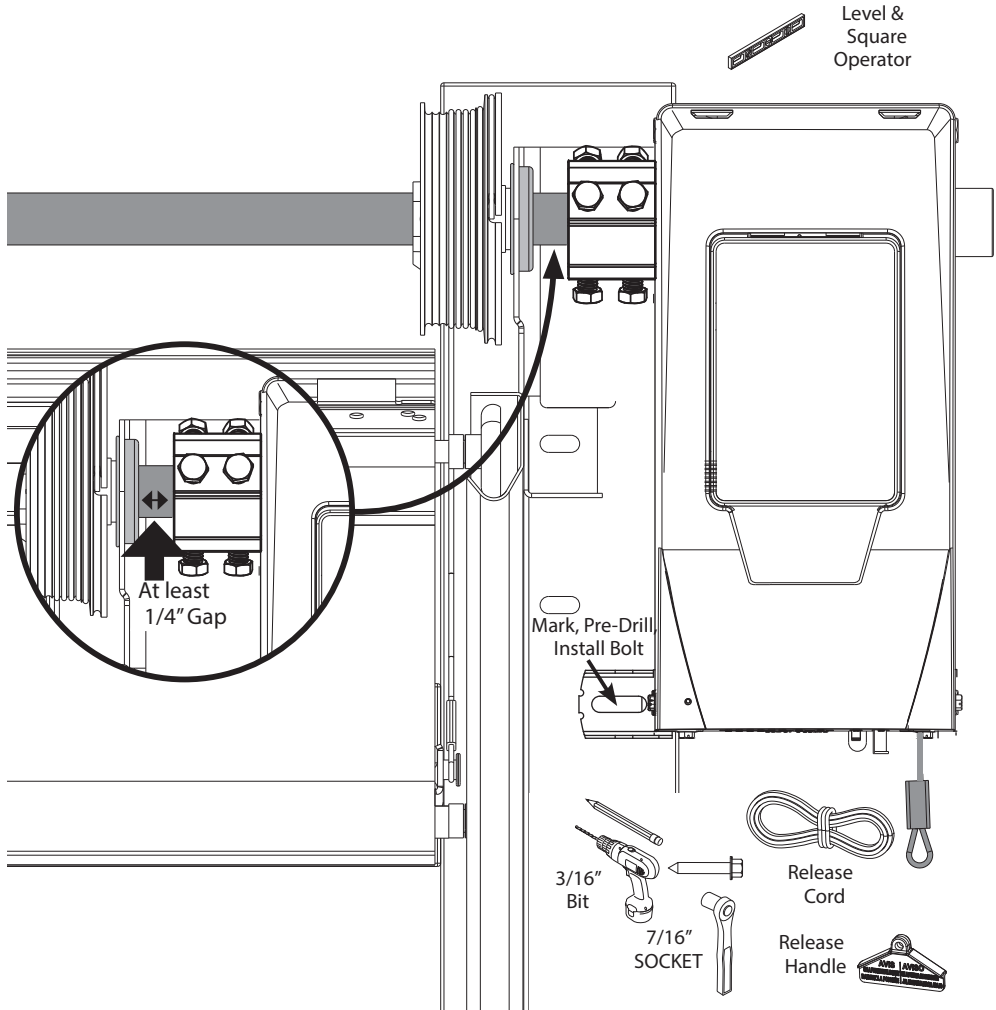

# INSTALLING THE DOOR LOCK

## Install Door Lock

Door lock prevents manual door operation and is important for garage security.

**NOTE:** Door lock should be installed no more than 10' away on the operator side of the door if possible.

1. Mount door lock onto door track above a roller on the second or third door panel from the floor.

If mounting position does not line up with pre-punched door lock bar cutouts as shown below:

- Remove template from the back page of the owners manual.
  - Apply door lock drilling template to the door track where the center 7/16" hole is approximately 3 inches above the door roller on the 2nd or 3rd door panel.
  - Drill two 9/32" holes for mounting and one 7/16" hole if using template. De-burr holes if required.
2. Position door lock and install two 1/4" X 9/16" track bolts and nuts. Install track bolt on inside of door track facing outward.

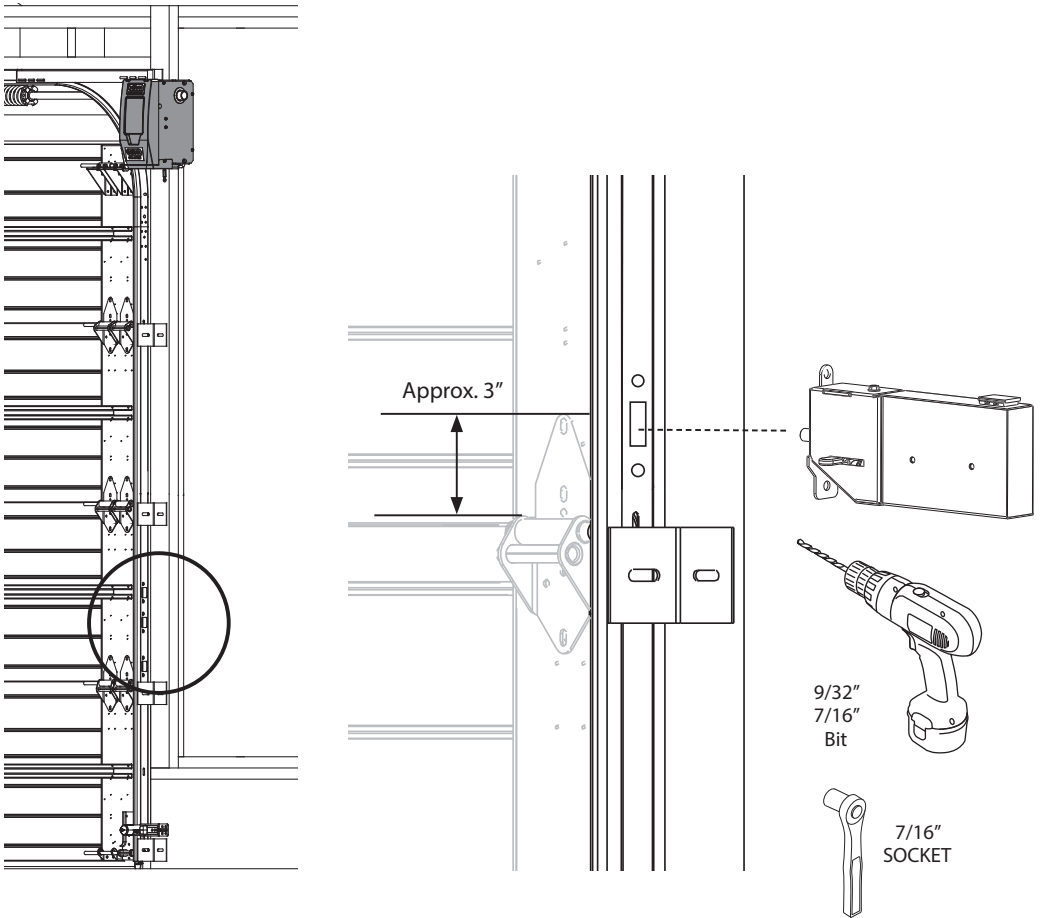

## Wire Door Lock

1. Plug door lock harness into the LOCK plug on bottom of opener. Insert plug in correct direction (see inset)
2. Run wire down the wall to the door lock and secure with supplied wire staples.

**NOTE:** Door lock wires are polarity sensitive.

3. Cut off excess wire, strip 1/4" of insulation and attach to bottom connectors on door lock.
4. Install WHITE wire to W terminal and STRIPED wire to B/W terminal.

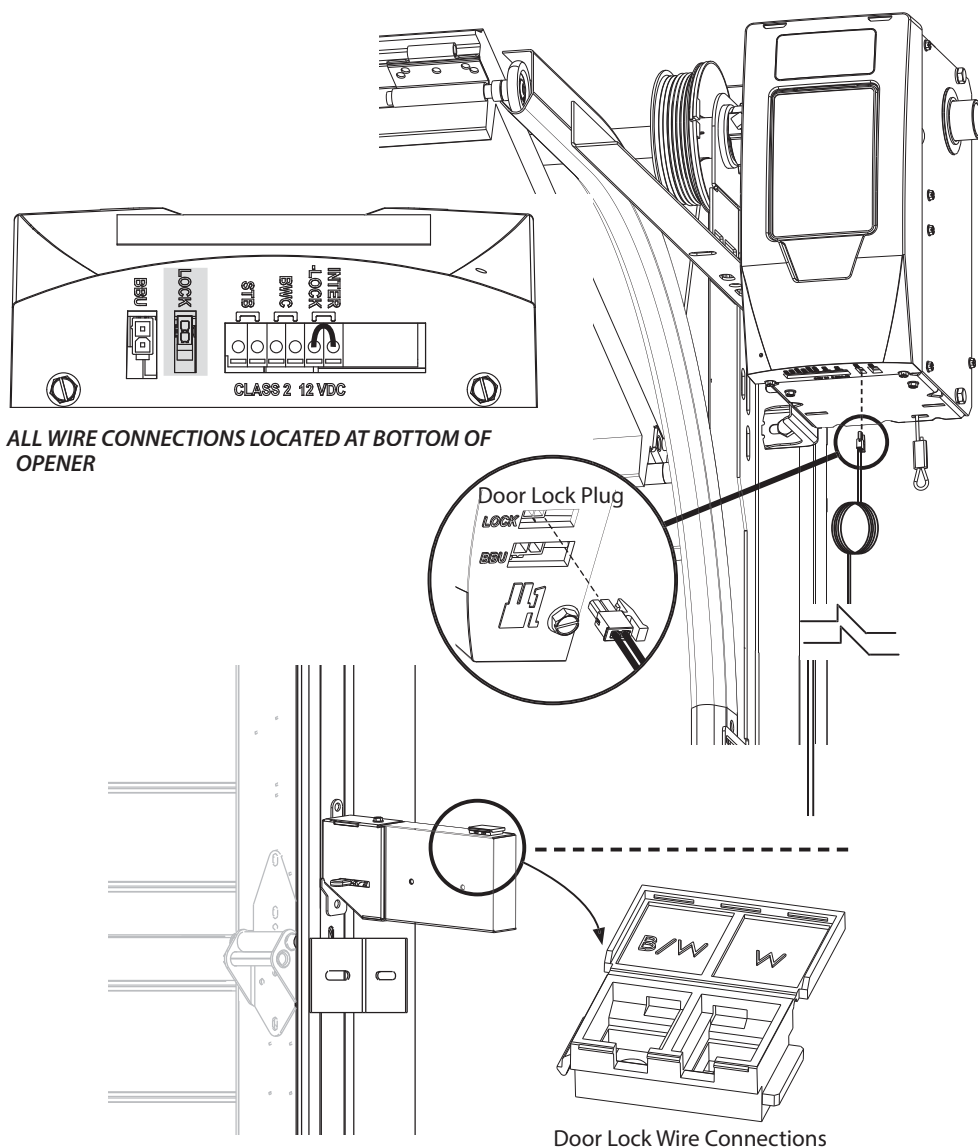

# WIRE THE OPENER (CONT')

## Install and Wire Safe-T-Beams® (STB)

1. Position Safe-T-Beam® (STB) Transmitter and Receiver on each side of garage door 5"- 6" above floor. Face the lenses towards each other.
2. Mark bracket mounting holes; drill 3/32" pilot holes and secure with 1/4" x 1-1/4" lag screws (provided) into wood. If mounting into concrete or block, other fasteners are required and are available at leading retail stores.
3. Route 2 lengths of supplied wire from powerhead, down to one sensor and along the header and down the side of the door to the other sensor. Secure the wire to the walls using the insulated staples.
4. On the powerhead: Remove 1/4" insulation from both sets of white and striped wire. Twist two white wires together. Using a small flat head screwdriver, press in the orange tab at one STB terminal and insert the wires. Twist the two striped wires together and insert into the other STB terminal. NOTE that STB wires are not polarity sensitive.
5. At each sensor, remove 1/4" insulation from the white and striped wires and secure in each screw terminal.

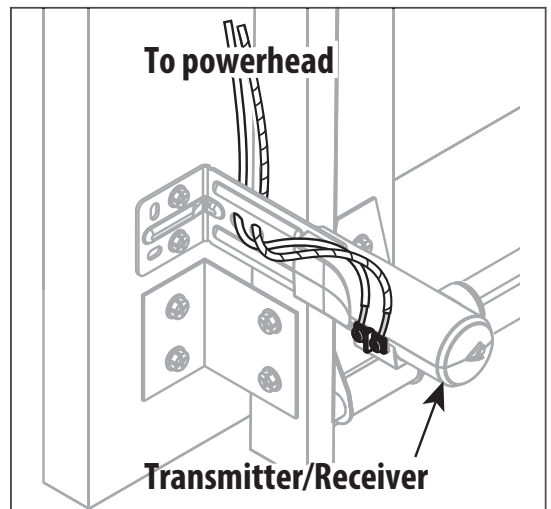
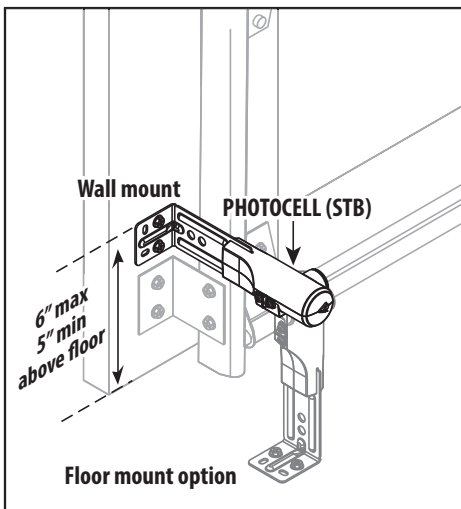
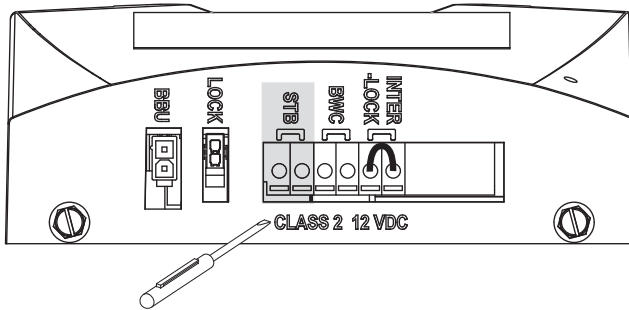



# FINISHING THE INSTALLATION

## Install Wireless Wall Console

1. Determine mounting location for wireless wall console.
2. Mount console no less than 5 feet above floor to prevent small children from activating opener.
3. Pre-drill 3/32" holes for mounting screws, or 3/16" if using drywall anchors (supplied) if needed.
4. Install bottom screw leaving a 1/8" gap.
5. Slide console onto screw and down slightly to lock in place.
6. Remove upper battery door and remove protective tab and batteries.
7. Install top screw to secure console to the wall.
8. Install batteries and battery door.
9. Install warning decal in the same area as wireless wall console.

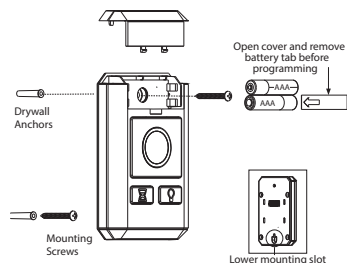

*Wireless Wall Console will automatically pair when opener is powered up.*

1. Wireless Wall Console is now paired to opener and will operate as normal.

## Wall Console Operation

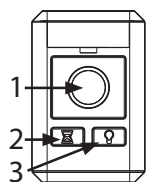

1. DOOR Button - Runs garage door opener.
2. DELAY Button - Adds a 10+ second delay for door operation. Press the delay button and door will automatically operate after set delay. Can be activated up to 3 times for a 10, 22 or 30 second delay.
3. LIGHT Button - Overrides the automatic timed light function of the garage door opener.

## Install Light Fixture

1. Determine mounting location within 30 feet of opener.
2. Pre-drill 3/32" holes for mounting screws, or 3/16" if using drywall anchors (supplied) if needed. 7-1/2 in. inches apart.
3. Install supplied screws leaving an 1/8" gap for mounting.
4. Route power cord through cutouts in flange and plug light into a standard 115V outlet. Secure excess wire under light housing.
5. Align LIGHT FIXTURE mounting holes with screws and turn light assembly to lock into place.

## Light Fixture Included With Opener:

1. Power up Wall Mount Opener.
2. Power LIGHT FIXTURE.

Light will automatically pair when opener is powered up.

3. LIGHT FIXTURE will flash and beep briefly.
4. LIGHT FIXTURE will flash again indicating that it is now paired to the opener.

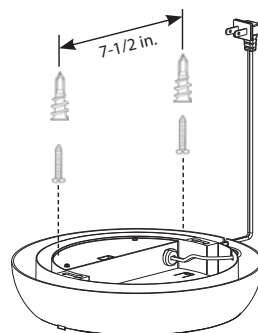

# FINISHING THE INSTALLATION

## Install and Wire Basic Wall Console (Hardwired) - Optional

1. Route supplied wire from powerhead to the desired location for the hardwired wall control. Secure wire with insulated staples.
2. On the powerhead: Remove 1/4" insulation from white and striped wire. Using a small flat head screwdriver, press in the orange tab and insert the white wire into BWC WHITE terminal and the striped wire into BWC BLACK terminal.
3. At the wall console end of the wire, remove 1/4" insulation from the white and striped wires and secure the white wire to the "W" terminal and the striped wire to the "B/W" terminal as shown.
4. Mark the wall console mounting holes, drill 3/32" pilot holes and mount with #6 x 1-1/4" screws. If mounting to drywall, anchors will be required (not provided).

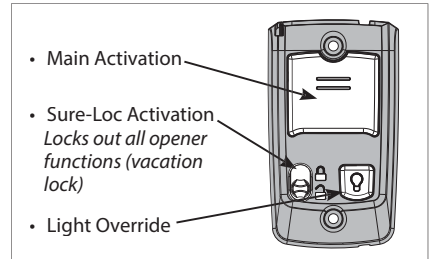
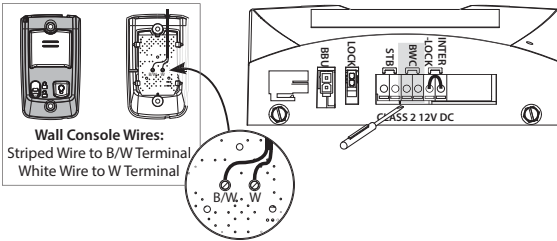

## Install and Wire N/C Interlock-Optional

1. **Do not remove factory installed interlock wire unless installing an interlock.** This jumper is required for proper opener operation.
2. Use of any commercially available normally closed (N/C) dry contact interlocks can be used with this opener. Using a small flat head screwdriver, press in the orange tabs at INTER-LOCK terminals and remove factory installed jumper wire and insert the interlock wires.

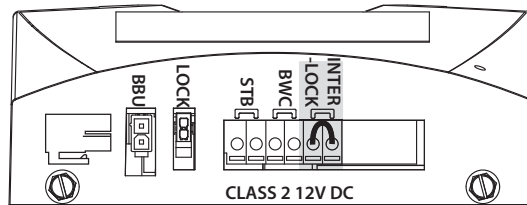

## Install Bottom Cover Onto Opener - OMIT THIS STEP IF INSTALLING BATTERY BACK-UP

1. Remove two screws on the bottom of opener.
2. Route wires to the rear of opener to align with slot in rear of cover.
3. Install cover with screws removed in step 1.

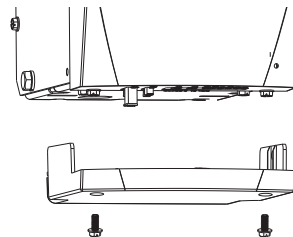

## FINISHING THE INSTALLATION

Apply power to opener

### CAUTION

**DO NOT** run opener until travel limits have been set to avoid damage to unit.

### CAUTION

NE PAS faire fonctionner l'ouvre-porte au-delà des limites de parcours pour ne pas endommager l'unité.

### WARNING

Opener is equipped with grounded electrical plug for your protection, and only fits grounded electrical outlets. **DO NOT** alter plug in any way! If you have no grounded outlets, have one installed by a licensed electrician. Opener must be properly grounded to prevent personal injury and equipment damage. **NEVER USE AN EXTENSION CORD!** Check local building codes for any requirement that you must have a permanent hard-wired connection.

### AVERTISSEMENT

L'opérateur, qui est équipé d'une prise électrique mise à la terre pour votre protection est compatible uniquement avec des prises électriques mises à la terre. NE PAS modifier la fiche d'une quelconque manière. Si vous n'avez pas de prises mises à la terre, faites-en installer par un électricien agréé. L'opérateur doit être correctement mis à la terre pour éviter les blessures corporelles et des dommages matériels. **NE JAMAIS UTILISER DE RALLONGE!** Vérifiez les codes locaux des bâtiments pour connexions câblées permanente. Les connexions câblées permanentes doivent être effectuées par un électricien agréé qui se servira d'outils appropriés et respectera les consignes.

#### FOR GROUNDED OUTLET CONNECTION:

Plug in the power cord to standard 115 VAC outlet. Coil excess cord and tape or twist tie it to top of powerhead.

**DO NOT USE EXTENSION CORDS TO POWER THIS OPENER.** Extended power input kits are available.

# 5

## OPENER PROGRAMMING & ACCESSORY INSTALLATIONS

**NOTE:** Before programming the opener, check to make sure there are no objects in the garage door opening. DO NOT allow persons to enter the area of the door while programming and operating.

The following steps list the order of programming the opener's functional settings as well as installation of any accessories that were included with the opener or purchased separately.

**These steps should be performed in order.**

1. Adjust opener speed for drum sizes.
2. Down Travel Limit
3. Up Travel Limit
4. Force Control
5. Contact Reverse test and adjustment
6. Remote Control Programming
7. Remote control(s), Lighting fixture and Wireless Wall Console included with this opener are programmed at the factory. The information provided on these pages should be used if adding additional remote controls, wireless wall consoles or light fixtures.
8. Accessory Installation and/or Programming
9. Program wireless keypad (If applicable)
10. Program built in vehicle remote (If applicable)
11. Program the Integrated Aladdin Connect™ (If applicable)
12. Install Battery Backup (BBU) (If applicable)

**NOTE:** When opener is activated to close, opener will start and stop slowly in small increments to detect cable tension then run at normal speed to close. This is normal operation.

Programming Button Layout

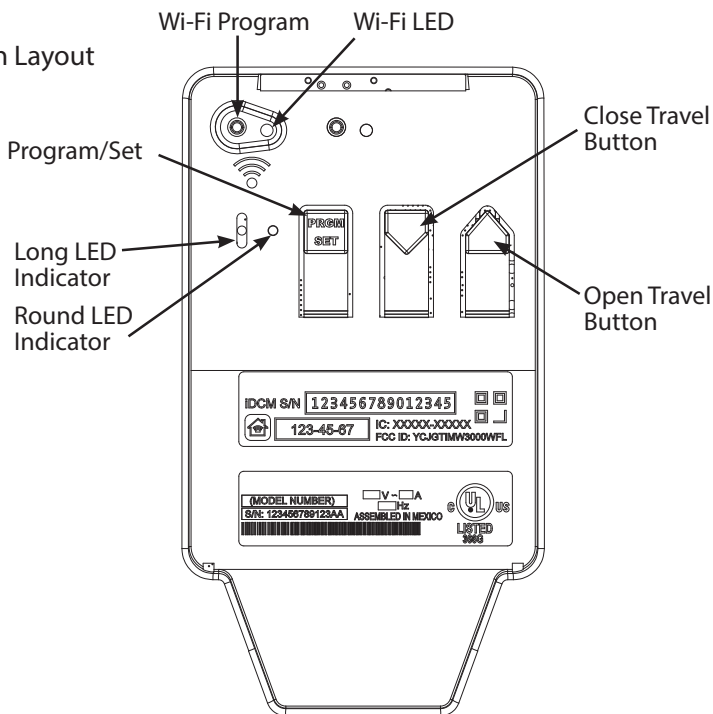

**NOTE:** Each programming step has a 30 second time limit for completion after the function is initiated. After 30 seconds, both LEDs will illuminate BLUE indicating time has expired and the step must be restarted. Restart the step as many times as necessary to complete the programming.

Remote controls, wireless keypads, wireless wall controls, and LED light programming will reset after 60 seconds.

# ADJUSTING FOR DRUM SELECTION

## ⚠ WARNING

Operator drum selection settings must be adjusted for use on Standard or High Lift residential doors with drum diameters greater than 4 inches. Drum selection settings must also be adjusted for use on residential Vertical Lift doors.

## ⚠ AVERTISSEMENT

Les réglages de sélection du tambour par l'opérateur doivent être ajustés pour une utilisation sur des portes résidentielles à levage régulier ou élevé avec des diamètres de tambour supérieurs à 4 pouces (10,16 cm). Les réglages de sélection du tambour doivent également être ajustés pour une utilisation sur des portes résidentielles à levage vertical.

### Drum Selection Settings

Drum selection settings are pre-programmed at the factory for 4" Standard Lift type drums. Drum selection must be made on doors with Standard or High Lift drums with a diameter greater than 4 inches, and also on Vertical Lift doors. There are two drum settings available for sectional doors. Please note that door speed may be affected by door weight, drum type, and balance, along with condition of door components and tracks. Proper selection of the drum type is important for proper operation of the opener.

#### TO CHANGE OPENER drum selection:

1. Press and hold the SET/PRGM button on the opener until both LEDs turn BLUE then release.
2. Press the UP button twice.
3. Press PRGM button once.
4. The current setting will now be displayed. (SEE CHART).
5. Press either UP or DOWN buttons to adjust setting (SEE CHART)
6. Press PGRM button once to lock in the selection. LEDs turn BLUE then off.
7. Opener is now ready to set limits.

### ⚠ IMPORTANT NOTICE ⚠

**IF DRUM SELECTION SETTING IS ALTERED, ALL FOLLOWING STEPS ON PAGES 19 THROUGH 21 MUST BE PERFORMED TO LOCK IN THE FORCE PROFILE FOR PROPER DOOR OPERATION.**

### DRUM SELECTION CHART

DRUM TYPE	Long LED	Round LED
Standard 4 inch or less diameter drum	RED	RED
Standard or High Lift greater than 4 inch diameter or Vertical Lift	PURPLE	PURPLE

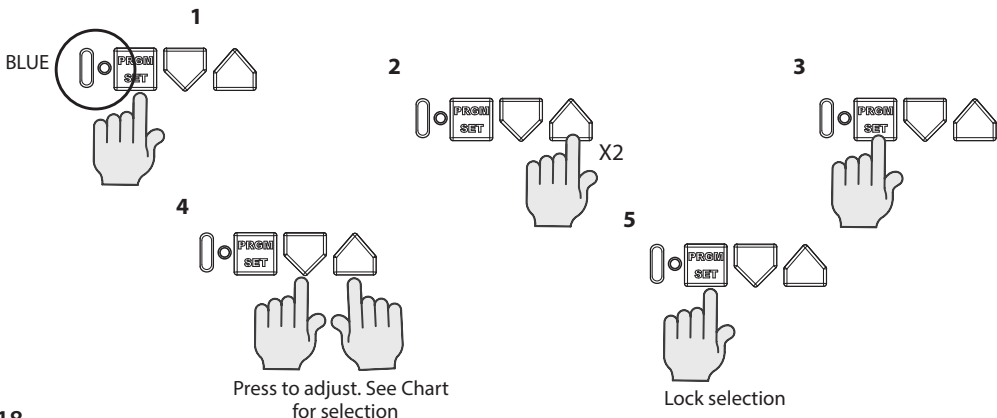

# PROGRAMMING THE DOWN LIMIT

## ⚠ WARNING

- Make sure doorway is in full view and clear of obstacles and people to avoid injury or property damage.
- DO NOT operate this unit from the wall control before LIMITS are set. Severe damage to the opener could occur.
- DO NOT set limits with Battery Backup attached. AC power MUST be connected to the opener while setting limits for proper operation.

**⚠ NOTE:** Door MUST be engaged to the opener prior to programming. Door should rest somewhere between full open and closed. **DO NOT START WITH DOOR FULLY OPEN OR CLOSED.**

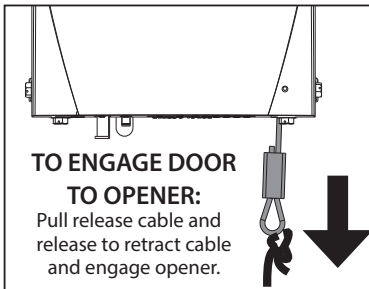

### Programming DOWN Limit:

1. Press and hold the DOWN arrow button on the operator for 2-5 seconds.
  - The long LED will turn blue. Release button.
  - The long LED will then flash blue.
2. Press and hold the DOWN arrow button until door is fully closed.

**NOTE:** Door should rest on the floor until the weather strip is compressed enough to seal along the width of the door. Damaged doors or uneven floors may not seal properly. Repair these conditions to achieve a proper seal. DO NOT compress seal so much that the door will bend or buckle.

3. Use both UP and DOWN buttons to adjust close travel as necessary until door is at the desired down limit position.
4. Press and release the SET/PRGM button
5. Both LEDs will flash blue then go out.
6. The down limit is now programmed.

## ⚠ AVERTISSEMENT

- S'assurer que le passage de la porte est visible et dégagé, à savoir sans obstacles ni personne afin d'éviter toute blessure potentielle ou dommage matériel.
- NE PAS utiliser cette unité avec la console murale avant d'avoir réglé les LIMITES. L'ouvre-porte pourrait subir de sérieux dommages.
- NE PAS fixer de limites en mode batterie de secours. L'alimentation CA DOIT être branchée sur l'ouvre-porte, pendant le réglage des limites, pour assurer un bon fonctionnement.

### 1-2. Enter Programming Mode

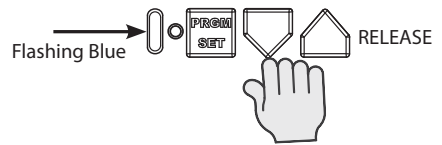
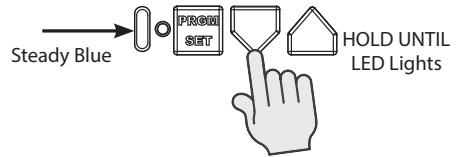

### 3. Adjust Door Position

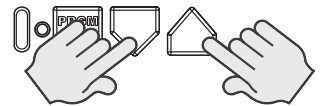

### 4. Lock Programming

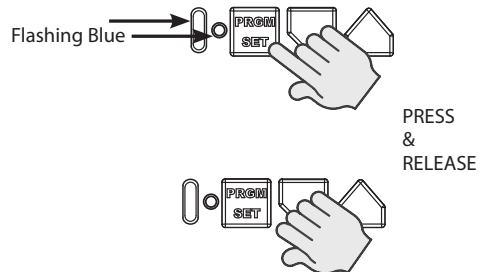

## ⚠ IMPORTANT NOTICE ⚠

**IF DOWN LIMIT SETTING IS ALTERED, ALL FOLLOWING STEPS ON PAGES 20 THROUGH 21 MUST BE PERFORMED TO LOCK IN THE FORCE PROFILE FOR PROPER DOOR OPERATION.**

# PROGRAMMING THE UP LIMIT

## Programming UP Limit:

1. Press and hold the UP arrow button on the operator for 2-5 seconds.
  - The long LED will turn blue. Release button.
  - The round LED will then flash blue.
2. Press and hold the UP arrow button until door is fully open.
3. Use both UP and DOWN buttons to adjust open travel as necessary until the door is at the desired up limit position.
4. Press and release the SET/PRGM button
5. Both LEDs will flash blue then go out.
6. The up limit is now programmed.

### 1-2. Enter Programming Mode

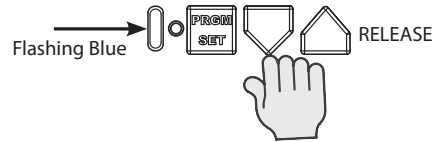
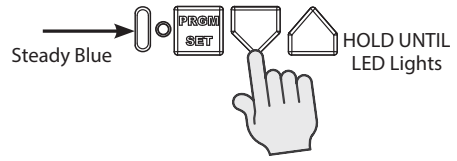

## SECTIONAL DOOR UP LIMIT:

*Door should fully open so that door seal is about even with door header. Do not adjust so much that the door will bend, buckle or stretch door spring cables backward.*

### 3. Adjust Door Position

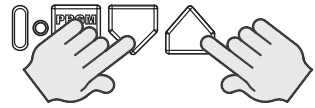

### 4. Lock Programming

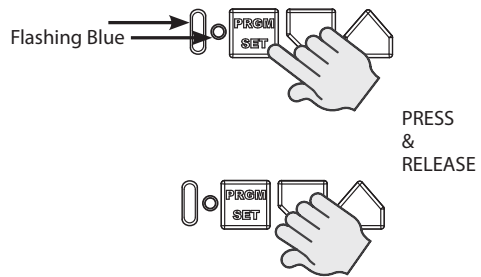

## ⚠ IMPORTANT NOTICE ⚠

**IF UP LIMIT SETTING IS ALTERED, ALL FOLLOWING STEPS ON PAGE 21 MUST BE PERFORMED TO LOCK IN THE FORCE PROFILE FOR PROPER DOOR OPERATION.**



# PROGRAMMING FORCE PROFILE & CONTACT REVERSE



## IMPORTANT NOTICE

**THIS STEP MUST BE PERFORMED FOR PROPER OPERATION!**

- Operate opener 2 full cycles up and down to set new opener profile.



## WARNING

### TO AVOID INJURY OR DAMAGE

**NEVER** adjust the force settings to adjust for damage, including an unbalanced door, binding door track or broken spring. Perform a CONTACT REVERSE TEST monthly.



## AVERTISSEMENT

### Pour éviter les blessures ou des dommages

**NE JAMAIS** régler la force pour compenser des dommages, y compris une porte mal équilibrée, un rail de porte coinçant ou des ressorts cassés.

Tous les mois, EFFECTUEZ LE TEST D'INVERSION AU CONTACT.

## SETTING FORCE PROFILE

1. Press and release the wall control button and allow the garage door to travel and stop at the DOWN limit.
2. Press and release the wall control button and allow the garage door to travel and stop at the UP limit.
3. Repeat steps 1 and 2 to complete this setting.

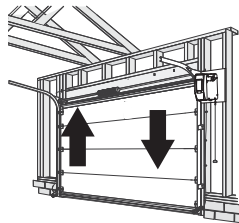
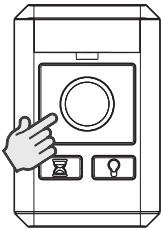

## Force Control Adjustments

Force settings are programmed from the factory to remain within safe parameters. These should not require adjustments. However, certain circumstances may require adjustment.

Refer to page 27 to adjust the force settings.

## Contact Reverse Test

**NOTE:** The limit and force settings **MUST BE COMPLETED** before performing the Contact Reverse Test.

1. With the garage door open, lay a 2" X 4" board flat on the floor at the center of the door opening.
2. Close the garage door using the wall control.

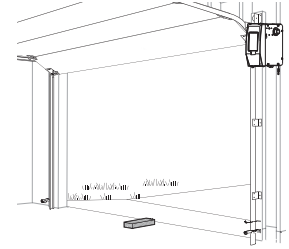

- When the door contacts the board, it should stop and reverse direction within 2 seconds to the full open position.
- The long LED light on the powerhead will begin to flash red with the reversal of the door.
- Remove the 2" x 4" board and operate the operator with the wall control again. This cycle will clear the flashing red LEDs.

## Contact Reverse Adjustment

If the door stops before contacting the board or if it does not reverse direction to fully open after contact with the board, it may be due to an improperly set DOWN limit. Verify settings by:

1. Repeat "Programming the Down Limit" section to make certain the door is closing tight against the floor.
2. Repeat the "Force Control" section on the left to set force limits.
3. Repeat the "Contact Reverse Test" above.
4. Repeat this process as needed until the door passes the contact reverse test.

Refer to page 27 to adjust the force settings.

# PROGRAMMING ADDITIONAL REMOTE CONTROLS

**THE REMOTE CONTROLS INCLUDED WITH THIS OPENER HAVE BEEN PROGRAMMED AT THE FACTORY FOR YOUR CONVENIENCE.**

**NOTE:** The following instructions are for remote control transmitters purchased separately (In addition to those provided with this opener) but can also be used if remote(s) require re-programming.

**NOTE:** Each programming step has a 30 second time limit for completion after the function is initiated. After 30 seconds, two LED's will illuminate RED indicating time has expired and the step must be re-started. Restart the step as many times as necessary to complete the programming.

**NOTE:** Each button on each remote must be programmed separately, following these steps.

1. Remove the battery's protective film from the remote by pulling straight down.
2. Press and hold the SET/PRGM button on the opener for 2-5 seconds.
  - The ROUND LED will turn BLUE. Release button.
  - The LONG LED will then flash PURPLE.
3. Stand at least 5 feet away from opener and slowly press and release the desired button on the remote two times. Both opener LEDs will flash and turn off indicating the remote has been programmed.
4. Press the desired remote button again. The opener should run.

To program the same remote for other garage door openers, repeat the steps above using one of the other remaining remote buttons.

## REPEAT STEPS 1 TO 4 FOR EACH OPENER AND REMOTE

**NOTE:** It is possible to press the remote button too quickly or lightly. If the LEDs do not go off, press the remote button several more times to achieve confirmation.

**BASIC PROGRAMMING IS COMPLETE AND YOUR GARAGE DOOR OPENER IS READY TO USE.**

See page 28 of this manual to erase remote devices from memory.

### 1. Activate Remote



### 2. Enter Programming Mode

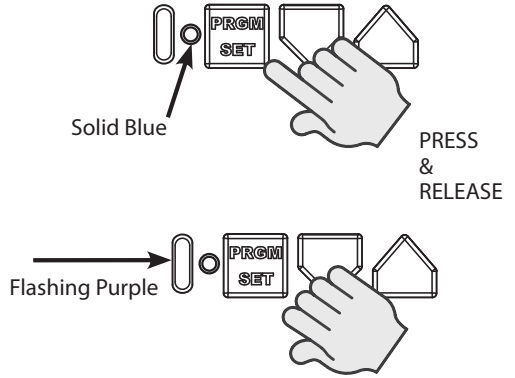

### 3. Press Remote Button Twice

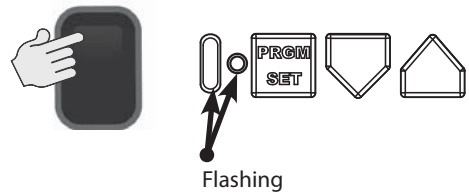

### 4. Test Remote

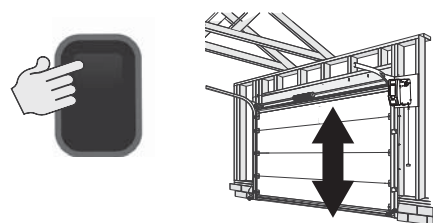

# PROGRAMMING ACCESSORIES (ABBREVIATED)

## QuickView Single Door Setup.

Please see complete instructions that accompany keypad

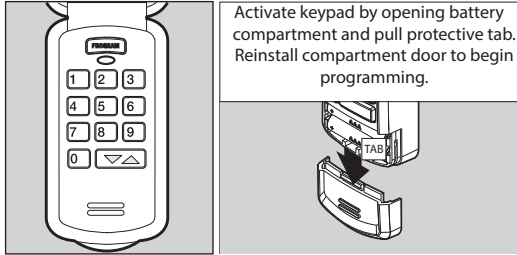

Program keypad before mounting.

### 1 Programming a PIN Number (Single Door)

**NOTE:** The existing factory default Personal Identification Number (PIN) for this keypad is the number sequence: 3-5-7

Sync the operator and the keypad by performing the following:

1. Ensure the keypad back lighting is off.
2. Place garage door operator into remote control PROGRAMMING MODE (see section 4).
3. Press 3-5-7 in sequence on the keypad.
4. Press the UP/DOWN key 3 to 4 times slowly until garage door operator operates.
  - This completes the programming of a single door operator (door 1) and keypad.
  - **IT IS RECOMMENDED THAT YOU CHANGE THIS PIN FROM THE EXISTING FACTORY DEFAULT SETTING of 3-5-7. See STEP 2 below.**

### 2 Changing Default PIN Of 3-5-7

1. Enter the factory default pin -3-5-7.
2. Press PROGRAM key once.
3. Enter a new PIN of your choice (3-8 digits).
4. Press PROGRAM key once.
  - Your PIN has been changed and your previous PIN will no longer operate the keypad or operator.

### 3 Operating the Keypad with the Operator

#### Single Door Operation:

1. Ensure number pad back lighting is off.
2. Enter PIN number.
3. Press the UP/DOWN key.
4. Operator will operate.

**NOTE:** Keypad will remain active for 15 seconds after a successful entry is made. During this 15 seconds ANY key will operate the operator.

### Resetting a PIN

Press and hold both the PROGRAM key and the Up/Down key for about five seconds.

The LEDs will slowly blink and then go out. When the LED stops blinking, the old programming has been successfully erased.

To create a new PIN, start with STEP 1.

### Mounting Keypad

The keypad **MUST** be mounted within sight of the garage door(s) at least five feet above the floor and clear of any moving door part.

1. Remove battery cover and batteries.

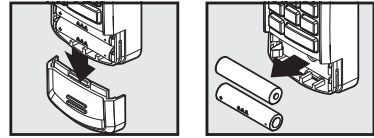

2. Drill 3/32" pilot hole for the top mounting screw (included).
3. Install a screw into the pilot hole, leaving a 1/8" gap between the screw head and wall.

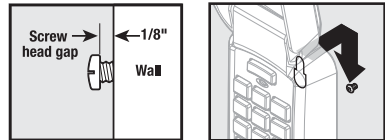

4. Hook the slotted mount, on back of keypad, over the screw.

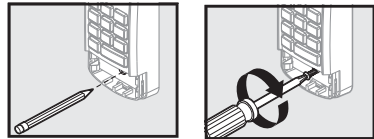

5. Mark and drill a pilot hole for the bottom screw (included) and secure keypad to wall (DO NOT overtighten).
6. Reinstall batteries and cover.

# PROGRAMMING VEHICLE CONTROLS (ABBREVIATED)

## Programming HomeLink® System

### 1 Clear HomeLink

Clear HomeLink by pressing and holding down the first and third buttons until the indicator on the HomeLink blinks slow and then fast for 20 seconds; then release both buttons.

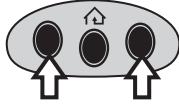

**NOTE:** Clearing the HomeLink will remove all previously programmed garage door operators.

### 2 Train HomeLink to the Remote

Choose the button on the HomeLink that will be used to open the door.

**NOTE:** Hold the Remote two inches from the HomeLink button.

Hold down the remote button. While holding, press and hold the chosen HomeLink button.



Hold down both buttons until the indicator on the HomeLink blinks slow then fast. Once it blinks, release both buttons.

### 3 Program HomeLink to the Operator

**(Place operator into programming mode - SEE PAGE 17)**

A. Press the chosen HomeLink button for two seconds and release. Press that same button again for two seconds and release. The long LED will flash blue and then turn off.

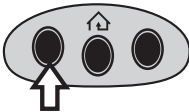

B. Press the HomeLink button a few more times until door moves.

**NOTE:** For additional instructions, see the motor vehicle manual, or visit [www.homelink.com](http://www.homelink.com) or visit [www.geniecompany.com](http://www.geniecompany.com)

## Programming Car2U® System

### 1 Clear Car2U to default settings

The default setting for the Car2U system is:

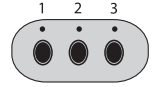

- Button 1 = Genie® Manufactured Operators
- Button 2 = LiftMaster® Manufactured Operators
- Button 3 = Wayne Dalton® Manufactured Operators

- A. Press and hold buttons 1 and 3 for 20 seconds or until all three LEDs begin to flash.
- B. Release both buttons. The Car2U system is now set to the Factory Default settings.

**NOTE:** Clearing the Car2U remote will remove all previously programmed garage door operators.

### 2 Program Car2U to the Operator (Place operator into programming mode - see section 4).

- A. Press the designated Car2U button for two seconds and release. Press that same button again for two seconds and release. The long LED will flash blue and then turn off.
- B. Press the Car2U button a few times more until door moves.

### 3 Changing Factory Default Button for a Genie® Operator

- A. Press and hold buttons 1 & 3 for one second and release all three LEDs will light solid red.
- B. Press and hold the button (2 or 3) to change it to the corresponding LED will flash. While continuing to hold that button, press and release button 1. Press and release button 1 again.
- C. Release the button being held in step B and wait for the LED to stop flashing. This button is now set. Repeat Step 2 for second operator.

# PROGRAMMING ALADDIN CONNECT™

**NOTICE:** The Aladdin Connect® feature will NOT operate unless the light fixture is installed and operational. Perform these steps only after opener and light fixture are fully installed, programmed and tested.

## IMPORTANT SAFETY INSTRUCTIONS

### WARNING

TO REDUCE THE RISK OF SEVERE INJURY OR DEATH, READ AND FOLLOW ALL INSTRUCTIONS.

1. Never allow children to operate or play with door controls.
2. Install the entrapment WARNING placard next to the wall control in a prominent location.
3. NO PERSONS SHOULD CROSS THE PATH OF A MOVING DOOR.
4. NEVER GO UNDER A STOPPED/PARTIALLY OPEN DOOR.
5. The Aladdin Connect™ operating system is designed for unattended operation. The door could move unexpectedly.

**SAVE THESE INSTRUCTIONS**

## CONSIGNES DE SÉCURITÉ IMPORTANTES

### AVERTISSEMENT

POUR RÉDUIRE LE RISQUE DE BLESSURES GRAVES VOIRE MORTELLES, LIRE ET COMPRENDRE TOUTES LES INSTRUCTIONS.

1. NE JAMAIS laisser les enfants utiliser ou jouer avec les commandes de l'ouvre-porte.
2. Placer l'étiquette d'AVERTISSEMENT en cas de coincage à proximité du bouton mural ou de la console murale de manière à ce qu'elle soit bien en évidence.
3. NE JAMAIS PASSER SOUS LA PORTE EN MOUVEMENT.
4. NE JAMAIS PASSER SOUS UNE PORTE À L'ARRÊT PARTIELLEMENT OUVERTE.
5. Le système d'exploitation Aladdin Connect™ a été conçu pour fonctionner sans surveillance. La porte peut se déplacer de façon inattendue.

**CONSERVER CES INSTRUCTIONS**

## Integrated Aladdin Connect™

The Aladdin Connect™ system is a convenient mobile device app to operate up to 20 garage door openers/controllers from Aladdin Connect™.

The Aladdin Connect™ app has the following features:

Up to 20 users for each account.

Sends notifications any time the garage door is operated from the app, wall console or remote control.

Show reports for opener usage showing dates and times when the opener was operated.

Show reports of who operated the opener when used from another user on the account.

Set custom RULES for predetermined times to automatically close a chosen door and/or notify of its operation.

Opener light system and an audible signal will activate as a warning that the opener is about to operate.



To use the Genie® Aladdin Connect™ app to control this garage door system follow these steps.

**Other home automation apps may also control this garage door opener system. Check our website at [www.geniecompany.com](http://www.geniecompany.com) for updates pertaining to compatible 3rd party apps.**

## 1 Check Wi-Fi Signal

**FOR ALL APPS - Use smart phone or other mobile device to check Wi-Fi signal strength.**

Hold the device near the garage door opener and check Wi-Fi meter on the device.

If signal is present, proceed to step 2 if using the Aladdin Connect™ app.

**Follow manufacturers instructions for other 3rd party apps.**

If signal is very weak or nonexistent, try the following:

Move Wi-Fi router closer to the garage.

Install a Wi-Fi range extender.

(Available at most electronics stores.)



## 2 Download the Aladdin Connect® app (Unless using 3rd party app)

### Scan for iOS app



Apple and the Apple logo are trademarks of Apple Inc., registered in the U.S. and other countries. App Store is a service mark of Apple Inc.

### Scan for Android app



## 3 Follow the Aladdin Connect® app instructions

Follow steps per the app instructions.

- Create an account
- Add a device
- Set up Wi-Fi
- Add users and rules

For help at any time contact The Genie Company at 1-866-599-4995 or visit our website. [www.geniecompany.com/aladdinconnect](http://www.geniecompany.com/aladdinconnect)



Scan the Aladdin Connect® QR Code on the front of this manual or on the powerhead when prompted by the Aladdin Connect® app.

## 4 Install WARNING placard

Place the included unattended operation warning placard next to the garage door opener's wall button.

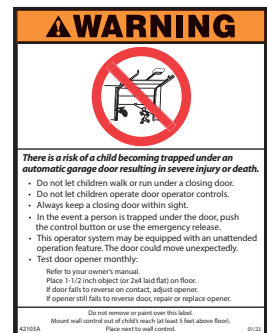

**NOTE:** Use of this product, the software embedded within this product and the related application software is subject to the Terms and Conditions available at: [www.geniecompany.com/aladdinconnect](http://www.geniecompany.com/aladdinconnect)

## CHANGING FORCE SETTINGS

**! WARNING****TO AVOID INJURY OR DAMAGE**

**NEVER** adjust the force settings to adjust for damage, including an unbalanced door, binding door track or broken spring.

Perform a CONTACT REVERSE TEST monthly.

**! AVERTISSEMENT****POUR ÉVITER LES BLESSURES OU DES DOMMAGES**

**NE JAMAIS** régler la force pour compenser des dommages, y compris une porte mal équilibrée, un rail de porte coinçant ou des ressorts cassés. Tous les mois, EFFECTUEZ LE TEST D'INVERSION AU CONTACT.

**! CAUTION**

**DO NOT** adjust force level above what is necessary to allow for normal door operation.

**! CAUTION**

**NE réglez PAS** la force à un niveau supérieur à ce qui est nécessaire pour permettre un fonctionnement normal de porte.

**! IMPORTANT NOTICE !**

**IF FORCE SETTING IS ALTERED, ALL STEPS ON PAGE 21 MUST BE PERFORMED TO LOCK IN THE FORCE PROFILE FOR PROPER DOOR OPERATION.**

**Force Settings:**

Force settings are pre-programmed at the factory to force level 6 (See Chart Below) and applied during the Open/Closed Limit settings steps. For normal use, these settings should not need adjustment.

Conditions possibly requiring adjustments are:

- Doors with very stiff weather seals.
- Doors that start down, stop, and reverse before closing.
- Doors that start up, but stop before they completely open.

1. Press and hold both UP & DOWN arrow buttons until the round LED turns red. Release buttons.
  - LEDs will show current force level (see chart).
2. Press either the UP or DOWN arrow button until the desired up force setting is shown (see chart).
3. Press & release the PRGM button to lock the desired up force setting.
  - Both LEDs will turn blue then go out confirming that the up force setting has been changed and is locked.
  - LEDs will now show the current down force setting (see chart).
4. Press either the UP or DOWN arrow button until desired DOWN force setting is shown (see chart).
5. Press & release the PRGM button to lock the desired down force setting.
  - Both LEDs will turn blue then go out confirming that the down force setting has been changed and is locked.
6. Perform all steps on page 36 to test operator.

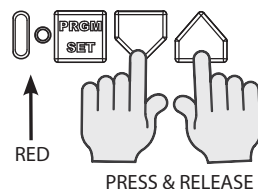

See Chart for  
Force level  
indicators.

FORCE SETTING CHART		
Force Level	Long LED	Round LED
1 (LOWEST)	OFF	BLUE
2	BLUE	OFF
3	BLUE	BLUE
4	OFF	PURPLE
5	PURPLE	OFF
6	PURPLE	PURPLE
7	OFF	RED
8	RED	OFF
9 (HIGHEST)	RED	RED

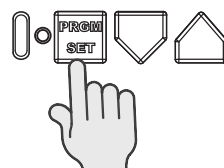

Press PRGM to  
lock settings



# SPECIAL INSTALLATION INFORMATION

## Clearing Memory of Remote Controls

**NOTE:** Clearing memory of remotes from the powerhead will clear ALL programmed remotes, wireless keypads and vehicle transmitters. The operator will no longer recognize any signal from any remote device, including a missing remote device. This does not include the Aladdin Connect® or wireless wall console.

All remaining (or recovered) remotes, vehicles and wireless keypads MUST be reprogrammed.

1. Press and hold the SET/PRGM button on the operator for 2-5 seconds.
  - The round LED will turn blue. Release button.
  - The long LED will then flash purple.
2. Press and hold the UP & DOWN buttons 2-5 seconds until both LEDs turn blue then release.
3. Both LEDs will turn off indicating that all remotes have been erased.
4. Press any remote button.
5. The operator should NOT run.

### 1. Enter Programming Mode

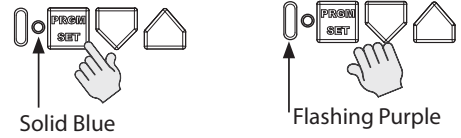

### 2. Press and Hold UP & DOWN Buttons 2-5 seconds



### 3. Test Remote



## Clearing Memory of Wireless Wall Console

1. Press and hold the SET/PRGM button on the operator for 2-5 seconds.
  - The round LED will turn blue. Release button.
  - The long LED will then flash purple.
2. Press and hold the UP & DOWN buttons 10+ seconds until both LEDs turn green then release.
3. Both LEDs will turn off indicating that all wireless wall consoles have been erased.
4. Press wall console button.
5. The operator should NOT run.

### 1. Enter Programming Mode

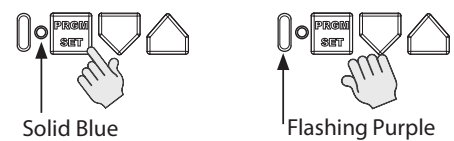

### 2. Press and Hold UP & DOWN Buttons 10+ seconds



### 3. Test Wireless Wall Console

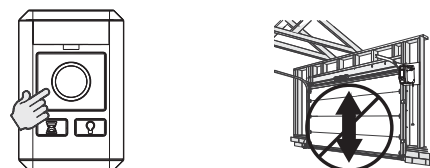

## Installing Safe-T-Beams® on multiple garage doors (Preventing “cross-talk”)

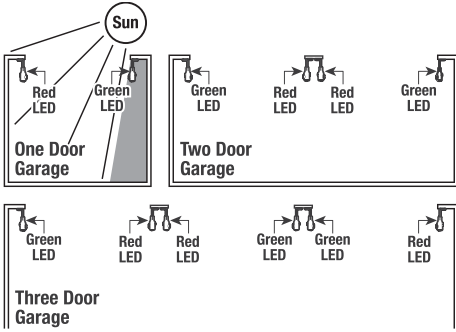

### Multiple Garage Doors

- NEVER position Safe-T-Beam® modules where signals will cross.
- Place the Transmitter (Red LED) Safe-T-Beams on adjacent doors facing in opposite directions.

**NOTE:** Direct sunlight creates interference with Safe-T-Beam® Receiver (Green LED). STB modules CAN be positioned further away from the door opening if necessary to avoid sunlight but no further off the wall to maintain alignment with the Transmitter (Red LED) module.

### Single Garage Door

- Determine which side of the garage receives direct sunlight.
- Position the Transmitter (Red LED) on the direct sunlight side.

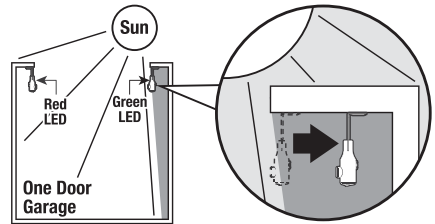

**NOTE:** Only use Safe-T-Beams® that are approved for use with this operator.

## Safe-T-Beam® Self-Diagnostic Troubleshooting Chart

Source (RED LED)	Sensor (Green LED)	Possible Problem	Solution
ON	ON	Normal Operation	None Required
OFF	OFF	Opener not powered Wiring from opener bad	Check breakers, fuses, plugs Check wiring for shorts
OFF	ON	Wiring to source missing or bad Power has been interrupted	Check wiring Remove power and reapply
2 BLINKS	ON	Beam not aligned Beam obstructed Sensor defective	Check source, Sensor alignment Check for obstruction Contact Customer Support
2 BLINKS	OFF	Wire to sensor missing or bad Sensor defective	Check wiring Contact Customer Support
3 BLINKS	ON	Sensor receiving interference	Determine source of interference Contact Customer Support

## Installing the Battery Back-up (BBU)

### Install Battery Backup (BBU) - (Optional)

1. Unplug power from operator.
2. Remove two screws securing bottom cover to operator head and remove cover.
3. Hold battery backup assembly at a 45 deg. angle near operator and route wires to back of operator between battery mounting tabs.
4. Insert rear tabs into slots on bottom of operator.
5. Plug connector of battery backup into the BBU connection on bottom of operator. Ensure connector is inserted in correct direction (SEE INSET).
6. Align battery backup to bottom of operator and secure with two screws removed in step 2.

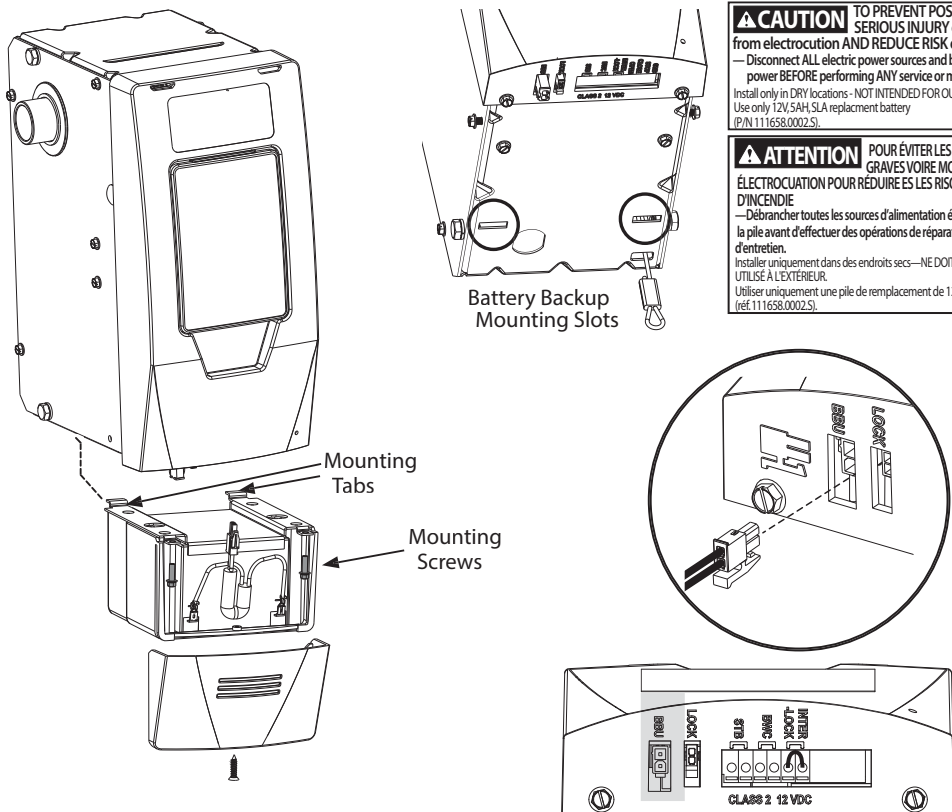

AC power must be present to set limits. DO NOT attempt to set limits or any other programming steps from battery power only.

### Testing the Battery Backup

**NOTE:** It is recommended that the battery backup be allowed to charge for 24 to 48 hours prior to testing. Initially, the operator may not operate from the battery backup mode if battery is not fully charged.

1. Run the operator using the wall control or remote to ensure it is working properly.
2. Turn off power to operator by unplugging from outlet or turning off breaker.
3. Press wall control or remote control. Operator will run at a slower speed than normal.

**NOTE:** See troubleshooting guide in this manual if any of the steps above fail.

4. After successful test, reconnect powerhead to power source.

## Programming Additional Accessories

The original wireless wall console and light kits are pre-programmed from the factory. However, if adding an additional WIRELESS WALL CONSOLE or LIGHT FIXTURE to this unit or either original require reprogramming for any reason, follow the instructions below.

### Wireless Wall Console

1. Press and hold the SET/PRGM button on the opener for 2-5 seconds.
  - The ROUND LED will turn BLUE. Release button.
  - The LONG LED will then flash PURPLE.
2. Press wall console main button 3 times slowly. Door should run.

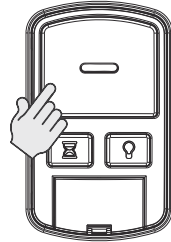

### Light Fixture Included with the Opener:

1. Power up Wall Mount Opener.
2. Power LIGHT FIXTURE.
3. LIGHT FIXTURE will flash and beep briefly.
4. LIGHT FIXTURE will flash again indicating that it is now paired to the opener.

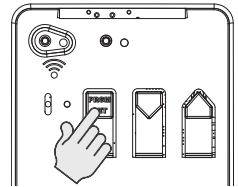

### Installing Additional Light Kits: (up to 3 Light Kits Total)

1. Press and hold the SET/PRGM button on the opener for two seconds.
  - The ROUND LED will turn BLUE. The LONG LED will then flash PURPLE.
2. Press the button on the LIGHT FIXTURE 1 time.
3. LIGHT FIXTURE will flash and beep.
4. LIGHT FIXTURE is now paired to opener and will operate as normal.

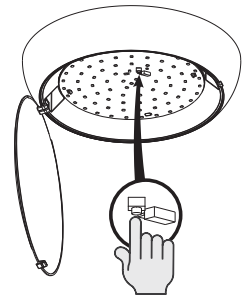

### Clearing Light Fixture Pair from the Opener

1. Ensure no other unpaired light fixtures are powered up in the vicinity except for the light you intend to pair.
2. Press and hold the SET/PGRM button on the opener until the long LED turns green.
3. Release the SET/PGRM button.

### Clearing Opener Pair from the Light Fixture

1. Ensure no other unpaired openers are powered up in the vicinity except for the opener you intend to pair.
2. Open lens cover on LED light fixture.
3. Press and hold light fixture pairing button for five seconds.
4. Release light fixture pairing button. The light fixture will beep for approximately two seconds to indicate the opener pairing has been cleared.

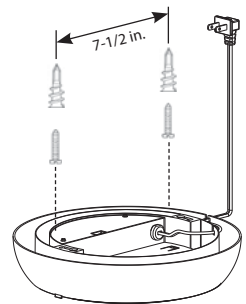

## WARNING

### IMPORTANT SAFETY INSTRUCTIONS

- This portable luminaire has a polarized plug (one blade is wider than the other) as a feature to reduce the risk of electric shock. This plug will fit in a polarized outlet only one way.
- If the plug does not fit fully in the outlet, reverse the plug. If it still does not fit, contact a qualified electrician.
- Never use with an extension cord unless plug can be fully inserted.
- Do not alter the plug.

## IMPORTANT SAFETY INSTRUCTIONS

### WARNING

**To reduce the risk of severe injury or death, read and follow all instructions.**

- NEVER** let children operate or play with the door controls.
- Keep remote away from children.
- ALWAYS** keep the moving door in sight and away from people and objects until door is completely closed. **NO ONE SHOULD CROSS THE PATH OF THE MOVING DOOR.**
- NEVER GO UNDER A STOPPED, PARTIALLY OPEN DOOR.**
- Test opener monthly. The door **MUST** reverse on contact with a 1-1/2" high object (or 2" x 4" board laid flat) at the center of the doorway on the floor. After adjusting either the force or limit of travel, retest door opener. Failure to adjust the opener properly may cause severe injury or death.
- When possible, use emergency release only when door is closed. Use caution when using this release with the door open. Weak or broken springs are capable of increasing the rate of door closing and increasing the risk of severe injury or death.
- KEEP DOORS PROPERLY BALANCED.** See your garage door Owner's Manual. An improperly balanced door increases the risk of severe injury or death. Have a trained door system technician make repairs to cables, spring assemblies, and other hardware.
- This operator system is equipped with an unattended operation feature. The door could move unexpectedly. **NO ONE SHOULD CROSS THE PATH OF THE MOVING DOOR.**

## SAVE THESE INSTRUCTIONS

## IMPORTANTES CONSIGNES DE SÉCURITÉ

### AVERTISSEMENT

**Pour réduire le risque de blessures graves voire mortelles, lire et comprendre toutes les instructions.**

- NE JAMAIS** permettre aux enfants d'actionner ou de jouer avec les commandes de la porte.
- Tenir les télécommandes hors de la portée des enfants.
- TOUJOURS** garder en vue la porte en mouvement et tenir à l'écart toute personne ou objet jusqu'à ce que la porte soit totalement fermée. **PERSONNE NE DOIT TRAVERSER LA TRAJECTOIRE D'UNE PORTE EN MOUVEMENT.**
- NE JAMAIS PASSER SOUS UNE PORTE À L'ARRÊT PARTIELLEMENT OUVERTE.**
- Tester l'ouvre-porte une fois par mois. La porte de garage **DOIT** inverser sa course au contact d'un objet de 4 cm (planche de 5 sur 10 cm) posé à plat sur le sol au centre de l'ouverture de la porte. Après avoir réglé la force ou la limite de la course, retenter l'ouvre-porte de garage. Un mauvais réglage de l'ouvre-porte peut entraîner des blessures graves voire mortelles.
- Utiliser, dans la mesure du possible le déclenchement d'urgence uniquement lorsque la porte est fermée. Utiliser le déclenchement d'urgence avec prudence lorsque la porte est ouverte. Des ressorts faibles ou brisés peuvent faire descendre la porte rapidement ce qui peut entraîner des blessures graves voire mortelles.
- VEILLER À CE QUE LA PORTE SOIT CORRECTEMENT ÉQUILIBRÉE.** Consulter le manuel du propriétaire de la porte de garage. Une porte déséquilibrée pourrait entraîner de graves blessures voire mortelles. Demander à un technicien spécialisé en système de portes de se charger des réparations des câbles, des ressorts et de toute autre quincaillerie.
- Ce système d'ouvre-porte est muni d'une fonction d'activation sans surveillance. La porte pourrait bouger sans que vous vous y attendiez. **IL NE FAUT JAMAIS PASSER DANS LA TRAJECTOIRE D'UNE PORTE EN MOUVEMENT.**

## CONSERVER CES INSTRUCTIONS

### WARNING

Use of any other wall control can cause unexpected operation of the door and loss of lighting feature. Locate wall console within sight of the door but far enough from door to prevent contacting it while operating the console. Control must be at least 5 feet above the floor to prevent small children from operating it.

### AVERTISSEMENT

L'utilisation d'une autre commande murale pourrait produire des résultats inattendus de la porte ainsi que le dysfonctionnement de l'éclairage. Localisez la console murale en vue de la porte et suffisamment loin de la porte pour éviter tout contact pendant l'utilisation de la console. La commande doit être à une hauteur minimale de 1,5 m au-dessus du sol afin que les jeunes enfants ne puissent pas l'atteindre.

Regular inspection/maintenance for the door and opener should be performed at regular intervals to ensure the system runs at peak safety, performance and efficiency.

MAINTENANCE ITEM	INTERVALS	DETAILS
Contact Reverse Test	Monthly	See Page 21 to run system test.
Lubricate Door Hardware	Monthly	Lubricate Rollers & Hinges with a light weight general purpose grease.
Safe-T-Beam® system check	Monthly	Check wiring for loose connections, cracks or worn insulation. Clean lenses of dirt & debris.
Door Balance	Monthly	See Maintenance Detail A
Battery Backup System	Monthly	Unplug opener from outlet. Test opener with remote or wall console. Replace battery if needed.
Remote Battery replacement	As Needed	See Maintenance Detail B

## A Door Inspection

*Perform the Door inspection as follows:*

With the door closed, pull manual emergency release handle DOWN to disengage opener from door.

1. Raise and lower the door manually. Door should move freely and smoothly.
2. Raise door manually about 3' to 4' feet from floor and let go.. Door should remain stationary or slowly drift closed. FIG. 1.

If door opens or closes rapidly, **CONTACT A TRAINED DOOR SYSTEM TECHNICIAN** to have your door springs serviced.

3. Close the door.
4. Pull emergency release cord down and release quickly to engage opener to door.
5. Operate door using remote or wall control.



### ! WARNING

Garage door hardware (springs, cables, brackets, pulleys, etc.) are under extreme pressure and tension. **DO NOT** attempt to repair or adjust door springs or any hardware, and **DO NOT OPERATE** garage door automatically or manually if door is improperly balanced or springs are broken. **CONTACT A TRAINED DOOR SYSTEM TECHNICIAN.**

### ! AVERTISSEMENT

La quincaillerie de la porte de garage (ressorts, câbles, supports, poulies, etc.) sont sous des pressions et des tensions extrêmes. **NE PAS** réparer ni régler les ressorts de la porte Ou toute autre pièce de quincaillerie et **NE PAS ACTIONNER** la porte manuellement ou automatiquement si elle n'est pas correctement équilibrée ou si des ressorts sont cassés. **CONTACTEZ UN TECHNICIEN SPÉCIALISÉ EN SYSTÈME DE PORTES**

## B Battery Replacement

Open case as shown, remove and replace CR2032 coin cell battery.

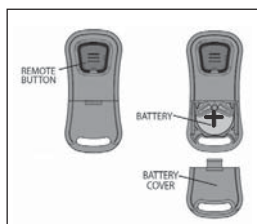

NOTE: Battery "+" sign orientation

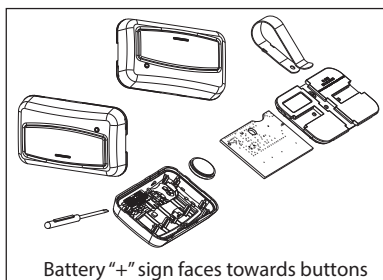
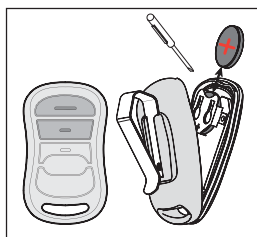

### Wall Console Battery Replacement

Replace wall console batteries with 2-AAA batteries.

1. Open remote case.
2. Replace batteries. Ensure insertion in correct position.
3. Align components and snap case closed.

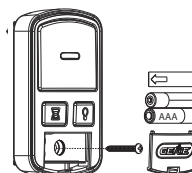



**Need help or have questions? Call Genie® at  
1-800-35-GENIE  
or visit: [www.geniecompany.com](http://www.geniecompany.com)**

**Opener does NOT operate when wall control is pressed.**

- Replace Wireless Wall Console Batteries, see page 33.
- If applicable, turn Sure-Lock™ OFF with Basic Wall Console, see page 15.
- Check power source
- If power is OK, check connections at powerhead terminals.
- Check for reversed, broken or cut wires. Staples can cut insulation and short wires. Repair or replace.

**Opener runs, but door does not move.**

- Ensure coupler set screws have not loosened, see poster.

**Opener works from wall control, but NOT from remote.**

- Check all remotes.
- Replace remote battery, see page 33.
- Program remotes to powerhead, see page 22.

**Remote has less than 25 feet operating range or no operation.**

- Relocate remote inside car and /or point remote at garage door.
- Replace remote battery, see page 33.
- Eliminate possible competing signals (radio, etc.).

**Door starts down, then STOPS and goes back up. OR Safe-T-Beam® System malfunction.**

- If NEW Installation, make sure ONLY the Safe-T-Beams® that came with this opener are installed.
- Check if limits are properly set, see pages 19-20. Adjust limits as needed.
- Check if Safe-T-Beam® red LED is flashing. See page 29, Safe-T-Beam® system check.
- Check Safe-T-Beam® system for beam obstruction or misalignment of lenses. See page 29, Safe-T-Beam® system.
- Check garage door for binding.
- Disconnect operator and try to manually close the door.
- If an operational problem exists, and opener will not close, the opener can be forced to close as follows: Press and hold the wall control button until door is completely closed.
- Check for interference from adjacent Safe-T-Beam® unit, see page 29.
- Check opener Door Lock and wire connections, see poster.
- Contact Genie® at 1-800-35-GENIE.



# TROUBLESHOOTING (CONT')

## **Door starts down, then STOPS before it is closed. OR Door will only open.**

- Check Safe-T-Beam® wire connection at powerhead and at STBs. See poster or page 29, Safe-T-Beam® system check.
- Check if limits are properly set, see pages 19-20. Adjust limits as needed.
- Check CONTACT REVERSE, see page 21.
- Check garage door for binding. See maintenance and adjustment, page 33.
- Check closing "FORCE" control, see page 21, and Force settings 27.
- Check opener Door Lock and wire connections, see poster.

## **Door starts up but STOPS before it is completely open.**

- Check if limits are properly set, see pages 19-20. Adjust limits as needed.
- Be sure door, opener, springs are in good repair, properly lubricated and balanced, page 33.
- Disconnect operator and try to manually open the door.
- Check closing/opening "FORCE" control, see page 21, and Force settings 27.
- If you suspect a problem with the garage door hardware or springs, visit [www.geniecompany.com](http://www.geniecompany.com) and use the "dealer locator" to hire a local door service professional. NEVER try to repair door hardware or springs yourself.
- Check opener Door Lock and wire connections, see poster.

## **Door will only run closed.**

- If applicable, turn Sure-Lock™ OFF with Basic Wall Console, see page 15.
- Check if limits are properly set, see pages 19-20.
- Check door balance, condition, and door spring, see page 33.
- Check opening "FORCE" control, see page 21, and Force settings 27.
- If you suspect a problem with the garage door hardware or springs, visit [www.geniecompany.com](http://www.geniecompany.com) and use the "dealer locator" to hire a local door service professional. NEVER try to repair door hardware or springs yourself.

## **Door opener starts for no reason.**

- Button stuck on wall control or remote.
- Was remote lost or stolen? Erase all remotes from powerhead memory and program new remotes, see page 28 and 22.

## **Noisy operation.**

- Be sure all door fasteners are tight, see poster.
- Be sure garage door is in good repair, properly lubricated and balanced, see page 33.
- Be sure opener is in good repair.

## **Door opener runs slow.**

- Check door balance, see page 33.
- Check operating condition of door. Door may need professional repair/adjustment.

# TROUBLESHOOTING (CONT')

## POWERHEAD LEDS

Powerhead LED		Possible Problem	Solution
Round LED	Long LED		
OFF	OFF	Normal operation.	None required.
		No response from unit.	Check power supply. Contact a trained door system professional.
ON/RED/ STEADY	ON/RED/ STEADY	Limits NOT set properly.	Re-program limits, see pages 19-20.
ON/RED/ FLASHING	ON/RED/ FLASHING	Program error.	Unplug unit, wait 5 seconds, plug in.
		Component failure.	Contact a trained door system technician.
ON/BLUE/ FLASHING	OFF	Remote NOT programmed.	Program remote, see page 22.
ON/PURPLE/ FLASHING	OFF	Remote NOT programmed.	Program remote, see page 22.
ON/RED/ FLASHING	OFF	Safe-T-Beam® physical obstruction.	Remote obstruction, recheck unit.
		Safe-T-Beam® signal interference.	Check alignment of Safe-T-Beam® pair and nearest other Safe-T-Beam® pair, see page 29.
OFF	ON/RED/ FLASHING	Door contact in UP or DOWN travel.	Remove obstruction.
		Door component failure detected.	Check door spring, track, rollers, hinges and fixtures.
OFF	ON/RED/ STEADY	Thermal cutout.	DO NOT unplug unit. Wait until LED clears before operating.
PULSING RED FLASH		Interlock Open	Check missing wire from interlock terminal Inspect interlock (see poster)
ON/PURPLE/ STEADY	ON/PURPLE/ STEADY	Component error.	Contact a trained door system technician.
OFF	ON/BLUE/ FLASHING	Door will not open.	Check Sure-Lock™. Sure-Lock™ should be OFF for normal operation (see page 15).
ON/PURPLE/ FLASHING	ON/PURPLE/ FLASHING	Radio receiver error.	Unplug the unit. Wait 5 seconds and plug the unit back in. If problems persist, contact a trained door system technician.
<b>LED SIGNALS with BATTERY BACK-UP installed</b>			
ON/GREEN STEADY	ON/GREEN STEADY	OK= Normal Operation. Charged, Battery Back Up	None Required
ON/GREEN FLASHING	ON/GREEN FLASHING	Discharging, Battery Back Up	Power is out. Battery in use.
ON/YELLOW FLASHING	ON/YELLOW FLASHING	Charging, Battery Back Up	None Required
ON/RED TO YELLOW FLASHING	ON/RED TO YELLOW FLASHING	Dead Battery, Battery Back Up	Replace Battery.

**Specify model number of opener when ordering parts**

DESCRIPTION	PART NUMBER
Hardware Bag	39946R.S
Cable Keeper Kit	39794A.S
Coupler	39830R.S
Door Lock	40760R.S
Door lock harness	40629A.S
Wireless Wall Console	39774R.S
Light Fixture	39945R.S
Low Voltage Power Input Kit	40984R.S
TorqueMaster® Adapter Kit	41032R.S
Alternate Mounting Kit	40803R.S

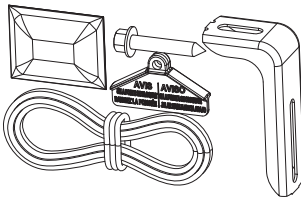

Hardware Bag

- Staples
- Lag Bolt
- Mounting Bracket
- Emergency Release Cord
- Emergency Release Handle

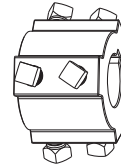

Coupler

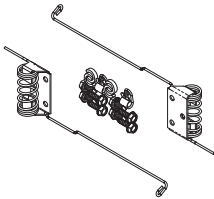

Cable Keeper Kit



Wireless Wall Console

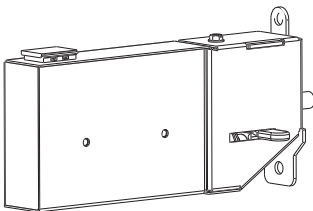

Door Lock

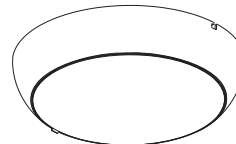

LED Light Fixture

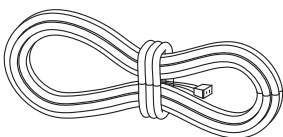

Door Lock Harness

# REPLACEMENT PARTS

**Specify model number of opener when ordering parts**

ITEM	DESCRIPTION	QTY
1	Housing Cover	1
2	Main Control Board Kit	1
3	Integrated Aladdin Connect® Control Board Kit	1
4	Transformer Kit	1
5	Chain assembly, 16 Loop, 1/2" P	1
6	Shaft Assembly Kit	1
7	Motor Assembly Kit	1
8	MLS (Travel Limit) Kit	1
9	Release Assembly Kit	1
10	Side Panel Assembly RH	1
11	Side Panel Assembly LH	1
12	Bottom Cover	1
13	Center Brace	1
14	Battery Backup Battery	1
15	Battery Backup housing	1

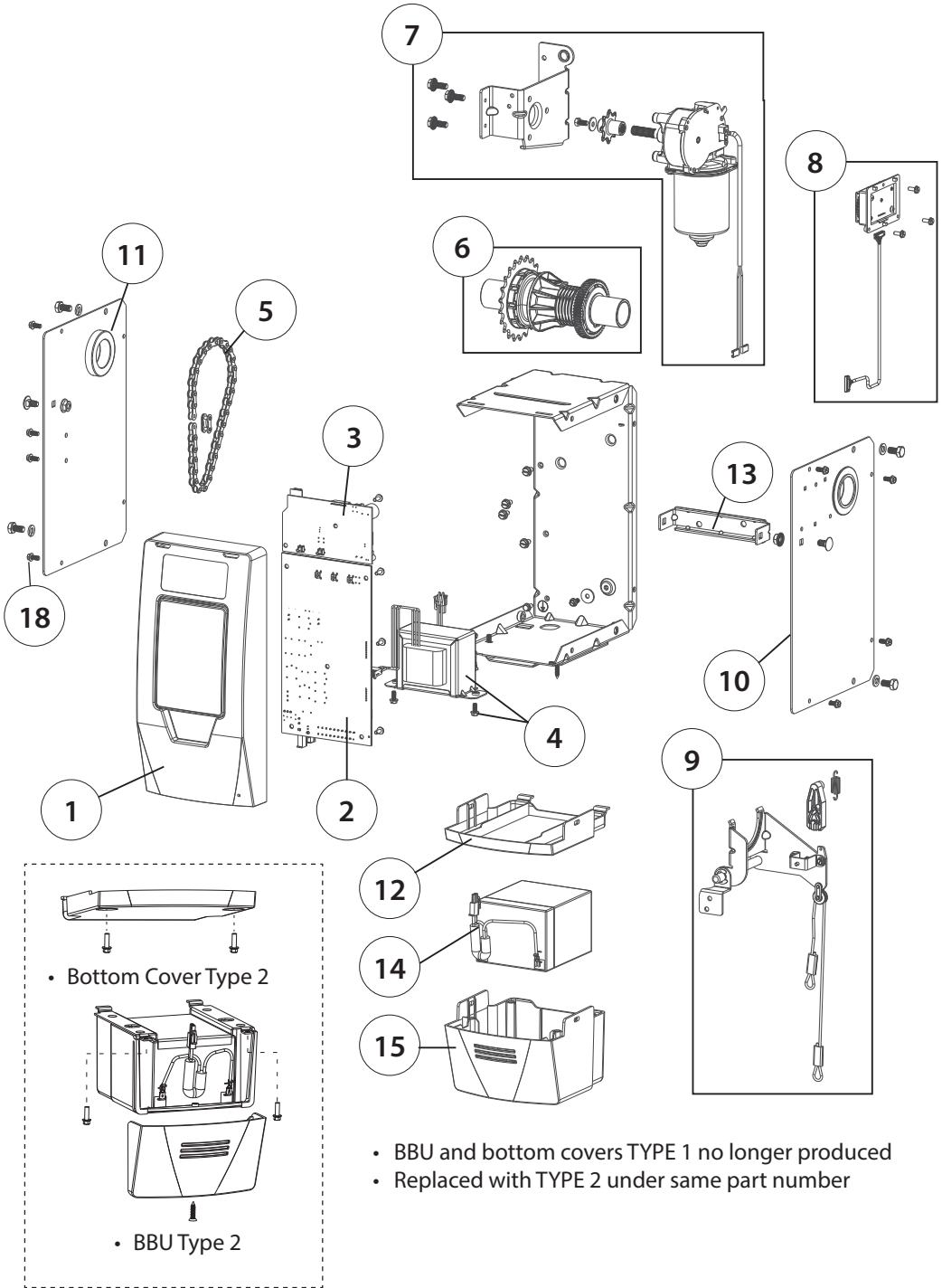

## Automatic Garage Door Opener Safety &amp; Maintenance Guide

## Garage Door Opener Safety - An Automatic Decision

**WARNING**

A garage door is the largest moving object in the home. An improperly adjusted garage door and opener can exert deadly force when the door closes – which could lead to entrapment of children or adults and subsequent injury or death.

Proper installation, operation, maintenance, and testing of the garage door and automatic opener are necessary to provide a safe, trouble-free system. Careless operation or allowing children to play with or use garage door opener controls are also dangerous situations that can lead to tragic results. A few simple precautions can protect your family and friends from potential harm. Please review the safety and maintenance tips in this guide carefully and keep it for reference. Check the operation of your garage door and opener to ensure they function in a safe and trouble-free manner. Be sure to read all Important Safety Information found in your garage door opener's manual as it provides more details and safety considerations than can be supplied with this guide.

**Garage Door Openers are Not Toys**

Discuss garage door and opener safety with your children. Explain the danger of being trapped under the door.

Stay away from a moving door.



The wall-mounted push button should be out of reach of children, at least 5 feet from the nearest standing surface and away from all moving parts. Mount and use the button where you can clearly see the closing garage door.



Keep transmitters and remote controls out of reach of children. Do not let children play with or use transmitters or other remote control devices.



Keep the door in sight until it completely closes when using the wall-mounted push button or transmitter.



# DASMA SAFETY GUIDELINES (CONT')

## Routine Maintenance Can Prevent Tragedies

Make monthly inspection and testing of your garage door and opener system a part of your regular routine. Review your owner's manual for both the door and door opener. If you don't have the owner's manuals, contact the manufacturer(s) and request a copy for your specific model(s). Look for the opener model number on the back of the power unit.

### **WARNING**

Springs are under high tension. Do not loosen or adjust any bottom brackets, red colored fasteners, cables, or supports. Only trained door system technicians should adjust these components.

#### Visually check the door and installation:

- Starting with the door in the closed position, use the manual disconnect on the opener to disconnect the door.
- Look for signs of wear or damage on hinges, rollers, springs, and door panels.
- These parts may require periodic lubrication. Check the owner's manual for suggested maintenance.
- If any signs of damage are evident, contact a trained door systems technician for assistance.
- Verify the photo eye height is no higher than 6" from the garage floor.



#### Test the door for proper operation:

- Open and close the door manually using handles or suitable gripping points.
- The door should move freely and without difficulty.
- The door should balance and stay partially open 3–4 feet above the floor.
- If you detect any signs of improper operation, contact a trained door systems technician for assistance.

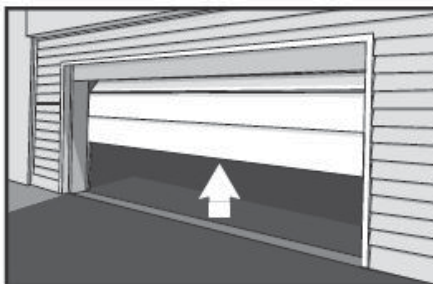

#### Test the opener safety features:

- Reconnect the opener to the door using the manual disconnect and open the door.
- Place a 2x4 board flat in the path of the door (1) and try to close it (2). The door should stop when it comes in contact with the 2x4 and then reverse direction.
- Block the photoelectric sensor by waving an object in front of the sensor and attempt to close the door. The door should not close unless the wall-mounted push button is manually held during operation.
- If the opener does not perform as described, contact a trained door systems technician for assistance.

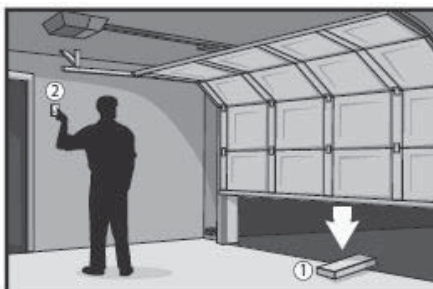



**The Genie Company**  
**1 Door Drive, Mount Hope OH. 44660**  
**1-800-35-GENIE**  
**[www.geniecompany.com](http://www.geniecompany.com)**

**DOOR LOCK TEMPLATE**